

SIGNIFICANT LAND & PRODUCING MINERALS AUCTION

18 Mineral Packages
4 Surface Tracts

Quality Rush Creek Bottomland Farm

6-Month Avg. Cash Flow \$196,376/Mo.

Producing SCOOP (Oil Window) Mineral Interests

Select Operators Include:

- Newfield Mid-Continent
- Sheridan Production Company
- Apache Corporation
- Merit Energy
- Casillas Operating
- Chaparral Energy



SURFACE TRACTS INFORMATION BOOKLET

THURSDAY, JANUARY 31 • 1:00 PM

800.451.2709

SchraderAuction.com

at The Springs Event Venue, Blanchard, OK • Online Bidding Available

DISCLAIMER

This Information Booklet has been assembled for purposes of the auction to be conducted on January 31, 2019 by Schrader Real Estate and Auction Company, Inc. ("Auction Company"). The information in this booklet includes information and materials obtained and/or derived from various sources, including Owner and third parties, regarding the property to be offered at the auction (the "Property").

The marketing materials prepared for this auction, including this Information Booklet, are not intended as a complete record of information pertaining to the Property, nor are they intended as a substitute for a complete and independent investigation and evaluation by a prospective bidder and its qualified advisers. All prospective bidders are responsible for obtaining their own independent technical and legal advice and for conducting their own independent investigation and evaluation of the Property and the information and materials provided with respect thereto.

AUCTION COMPANY AND ITS AGENTS AND REPRESENTATIVES MAKE NO REPRESENTATION OR WARRANTY REGARDING THE PROPERTY OR AS TO THE ACCURACY OF ANY INFORMATION, MATERIALS AND/OR REPORTS PROVIDED IN CONNECTION WITH THIS AUCTION FROM ANY SOURCE.

Auction Company: Schrader Real Estate and Auction Company, Inc.

4% Buyer's Premium

AUCTION
MANAGER

BRENT WELLINGS • 972-768-5165 • brent@schraderauction.com

Summary of Terms:

BIDDING PROCEDURE: All tracts will be offered individually, in any combination and as a whole unit. Bidding on individual tracts and all combinations will compete until the end of the auction. The final bids are subject to Seller's acceptance or rejection.

PURCHASE CONTRACT: Immediately following the close of bidding, each high bidder will sign purchase contract documents in the forms provided in the bidder packets. All statements and information in the marketing materials are subject to the terms and conditions of the purchase contract documents. Seller shall not be bound by any statement, promise or inducement that is not contained in the purchase contract documents.

BUYER'S PREMIUM: The purchase price will be the bid amount plus a 4% buyer's premium.

PAYMENT: 10% of the purchase price will be due as a down payment on the day of auction, with the balance due at closing. The down payment may be made in the form of cashier's check, personal check or corporate check. **YOUR BIDDING IS NOT CONDITIONAL UPON FINANCING**, so be sure you have arranged financing, if needed, and are capable of paying cash at closing.

CLOSING: The targeted closing period is on or before March 4, 2019.

Surface Tracts:

POSSESSION: Possession will be delivered at closing except that possession of the cropland will be delivered subject to harvest of the existing wheat crop.

REAL ESTATE TAXES: Real estate taxes will be prorated to the date of closing.

DEED: The Surface Tracts will be conveyed by a deed without warranty, excluding all minerals. (Any purchased Mineral Tracts will be conveyed by a separate mineral deed.)

EVIDENCE OF TITLE: Seller will furnish preliminary title insurance schedules before the auction and an updated title insurance commitment before closing. Buyer will pay for the issuance of any title insurance policy.

SURVEY: A new survey will be obtained only if necessary to record the conveyance or if otherwise deemed appropriate in Seller's sole discretion. If a new survey is obtained, the survey cost will be shared equally by Seller and Buyer and, unless otherwise provide in the purchase contract documents, the purchase price will be adjusted proportionately to reflect any difference between advertised and surveyed acres.

TRACT MAPS; ACRES: Tract maps and advertised acres are approximations based on existing tax parcel data, legal descriptions &/or aerial mapping data and are not provided as survey products.

Mineral Tracts:

DEED: The Mineral Tracts will be conveyed by a mineral deed without warranty. With respect to any particular Mineral Tract, the Buyer will acquire all of Seller's right, title and interest with respect to the minerals in and under and that may be produced from the particular land identified with such Mineral Tract. The form of mineral deed will be available to review prior to the auction.

EVIDENCE OF TITLE: Seller has no obligation to provide a mineral title search report or opinion before or after the auction. A prospective bidder is responsible for examining the title prior to the auction. In any event, Buyer agrees to accept title in its current condition and accept the deed without any warranty of title, express or implied.

ASIS: Mineral Tracts are offered on an as-is, where-is basis. No representation or warranty is or will be made for any purpose whatsoever as to the quality, quantity, usability, suitability, mineability, value or condition of any minerals which may or may not be included with the purchased Minerals Tract(s).

All Tracts:

ALL PROPERTY IS OFFERED "AS IS, WHERE IS". NO WARRANTY OR REPRESENTATION, STATED OR IMPLIED, IS MADE BY SELLER OR AUCTION COMPANY CONCERNING THE PROPERTY. Prospective bidders are responsible for conducting their own independent inspections, investigations, inquiries and due diligence concerning the property. The information contained in the marketing materials is provided in order to facilitate (and not as a substitute for) a prospective bidder's pre-auction due diligence. All marketing materials are subject to a prospective bidder's independent verification. Seller and Auction Company assume no liability for any inaccuracies, errors or omissions in such materials. All sketches and dimensions are approximate.

AGENCY: Schrader Real Estate and Auction Company, Inc. and its representatives are exclusively the agents of Seller.

CONDUCT OF AUCTION: The conduct of the auction and increments of bidding will be at the direction and discretion of the auctioneer. Seller and its agents reserve the right to preclude any person from bidding if there is any question as to the person's identity, credentials, fitness, etc. All decisions of the auctioneer at the auction are final.

CHANGES: Please arrive prior to scheduled auction time to review any changes and/or additional information. **THE PURCHASE CONTRACT DOCUMENTS (INCLUDING THE FINAL AUCTION DAY ANNOUNCEMENTS) WILL SUPERSEDE THE MARKETING MATERIALS AND ANY OTHER PRIOR STATEMENTS.**



950 N. Liberty Dr., Columbia City, IN 46725
800.451.2709 | 260.244.7606
www.schraderauction.com

Follow us and download our new Schrader iOS app



BOOKLET INDEX

Real Estate Auction Registration Forms

Location Map

Tract Map & Descriptions

Soils Maps

Topography Map

Flood Zone Map

Title Commitment

Tax Cards

Property Photos

BIDDER PRE-REGISTRATION FORM

THURSDAY, JANUARY 31, 2019
237 ACRES – LINDSAY, OKLAHOMA

For pre-registration, this form must be received at Schrader Real Estate and Auction Company, Inc.,
P.O. Box 508, Columbia City, IN, 46725,
Fax # 260-244-4431, no later than Thursday, January 24, 2019.
Otherwise, registration available onsite prior to the auction.

BIDDER INFORMATION

(FOR OFFICE USE ONLY)

Name _____

Bidder # _____

Address _____

City/State/Zip _____

Telephone: (Res) _____ (Office) _____

My Interest is in Tract or Tracts # _____

BANKING INFORMATION

Check to be drawn on: (Bank Name) _____

City, State, Zip: _____

Contact: _____ Phone No: _____

HOW DID YOU HEAR ABOUT THIS AUCTION?

Brochure Newspaper Signs Internet Radio TV Friend

Other _____

WOULD YOU LIKE TO BE NOTIFIED OF FUTURE AUCTIONS?

Regular Mail E-Mail E-Mail address: _____

Tillable Pasture Ranch Timber Recreational Building Sites

What states are you interested in? _____

Note: If you will be bidding for a partnership, corporation or other entity, you must bring documentation with you to the auction which authorizes you to bid and sign a Purchase Agreement on behalf of that entity.

I hereby agree to comply with terms of this sale including, but not limited to, paying all applicable buyer's premiums, and signing and performing in accordance with the contract if I am the successful bidder. Schrader Real Estate and Auction Company, Inc. represents the Seller in this transaction.

Signature: _____ Date: _____

Online Auction Bidder Registration
237± Acres • Lindsay, Oklahoma
Thursday, January 31, 2019

This form and deposit are only required if you cannot attend the auction and wish to bid remotely through our online bidding system.

This registration form is for the auction listed above only. The person signing this form is personally responsible for any bids placed on the auction site, whether bidding on behalf of their personal account or on behalf of a corporation or other third party. If you are bidding on behalf of a third party, you are responsible for obtaining the necessary documentation authorizing you to bid on behalf of the third party. Schrader Real Estate and Auction Co., Inc. will look to the herein registered bidder for performance on any bid placed on this auction if you are the successful high bidder.

As the registered bidder, I hereby agree to the following statements:

1. My name and physical address is as follows:

My phone number is: _____

2. I have received the Real Estate Bidder's Package for the auction being held on Thursday, January 31, 2019 at 1:00 PM.
3. I have read the information contained in the Real Estate Bidder's Package as mailed to me or by reading the documents on the website (www.schraderauction.com) and understand what I have read.
4. I hereby agree to comply with all terms of this sale, including paying all applicable buyer's premiums, and signing and performing in accordance with the Real Estate Purchase Agreement if I am the successful bidder.
5. I understand that Schrader Real Estate and Auction Co., Inc. represent the Seller in this transaction.
6. I am placing a deposit with Schrader Real Estate and Auction Co., Inc. Escrow in the amount of \$_____. I understand that the maximum bid or combination of bids I place may not exceed an amount equal to ten times the amount of my deposit. My deposit is being conveyed herewith in the form of a cashier's check payable to Schrader Real Estate and Auction, Co., Inc. Escrow or via wire transfer to the escrow account of Schrader Real Estate and Auction, Co., Inc. per the instructions below. I understand that my deposit money will be returned in full via wire transfer on the next business day if I am not the successful high bidder on any tract or combination of tracts.

Schrader Real Estate & Auction Company, Inc.
950 North Liberty Drive / P.O. Box 508, Columbia City, IN 46725
Phone 260-244-7606; Fax 260-244-4431

For wire instructions please call 1-800-451-2709.

7. My bank routing number is _____ and bank account number is _____.
(This for return of your deposit money). My bank name, address and phone number is:

8. **TECHNOLOGY DISCLAIMER:** Schrader Real Estate and Auction Co., Inc., its affiliates, partners and vendors, make no warranty or guarantee that the online bidding system will function as designed on the day of sale. Technical problems can and sometimes do occur. If a technical problem occurs and you are not able to place your bid during the live auction, Schrader Real Estate and Auction Co., Inc., its affiliates, partners and vendors will not be held liable or responsible for any claim of loss, whether actual or potential, as a result of the technical failure. I acknowledge that I am accepting this offer to place bids during a live outcry auction over the Internet *in lieu of actually attending the auction* as a personal convenience to me.

9. This document and your deposit money must be received in the office of Schrader Real Estate & Auction Co., Inc. by **4:00 PM, Thursday, January 24, 2019**. Send your deposit and return this form via fax to: **260-244-4431**.

I understand and agree to the above statements.

Registered Bidder's signature

Date

Printed Name

This document must be completed in full.

Upon receipt of this completed form and your deposit money, you will be sent a bidder number and password via e-mail. Please confirm your e-mail address below:

E-mail address of registered bidder: _____

Thank you for your cooperation. We hope your online bidding experience is satisfying and convenient. If you have any comments or suggestions, please send them to:
kevin@schraderauction.com or call Kevin Jordan at 260-229-1904.

THURSDAY, JANUARY 31 • 1:00 PM

LOCATION MAP

800.451.2709
SchraderAuction.com

 **SCHRADER**
Real Estate and Auction Company, Inc.

LOCATION MAP

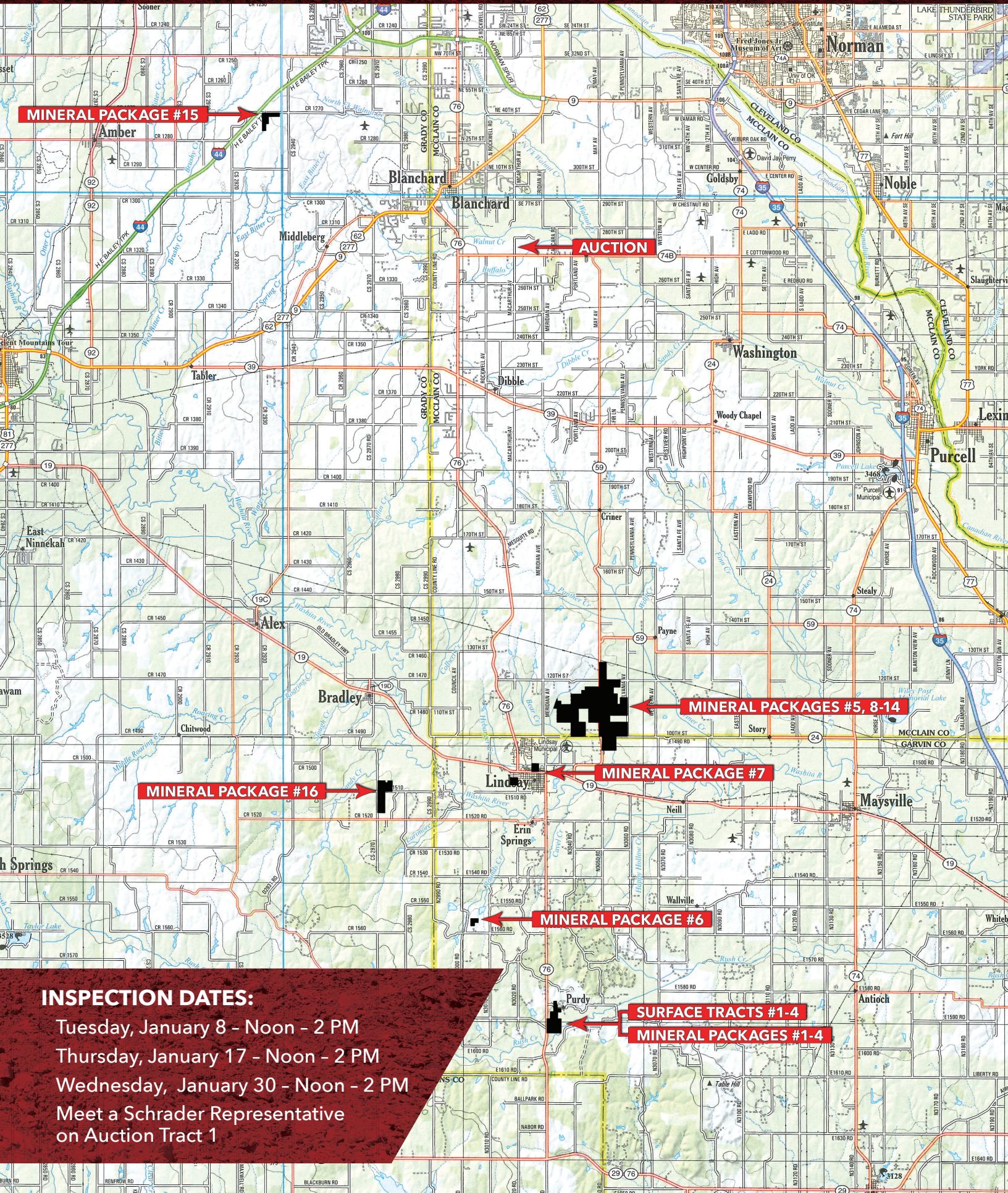

INSPECTION DATES:

Tuesday, January 8 - Noon - 2 PM

Thursday, January 17 - Noon - 2 PM

Wednesday, January 30 - Noon - 2 PM

Meet a Schrader Representative
on Auction Tract 1

THURSDAY, JANUARY 31 • 1:00 PM

TRACT MAP & DESCRIPTIONS

800.451.2709
 **SchraderAuction.com**

 **SCHRADER**
Real Estate and Auction Company, Inc.

TRACT MAP & DESCRIPTIONS

Garvin County, Twp 3 N, Range 4 W, Sec 23 & 26

A productive Rush Creek Bottomland farm in Garvin County, which consists of 233± acres, near the community of Purdy, Oklahoma. a stand-alone quality property, that will be offered in 4 individual tracts ranging from 10.5± to 155.5± acres. The farm boasts 140.57 tillable acres per FSA, with the balance of the farm being pasture, mature timber, comfortable home and 2 hay sheds.

TRACT 19: 10.5± acres that includes a comfortable 3 bedroom, 2 bath home.

TRACT 20: 17± acres of diverse terrain including a hay meadow and creek bottom which transitions into wooded hillside.

TRACT 21: 155.5± acres that include approximately 100 acres of tillable land with the balance in mature timber and pasture which borders along Rush Creek to the east and Highway 76 to the west.

TRACT 22: 50± acres with two 50' x 64' pole style hay barns and a blend of timber and approximately 35 tillable acres.

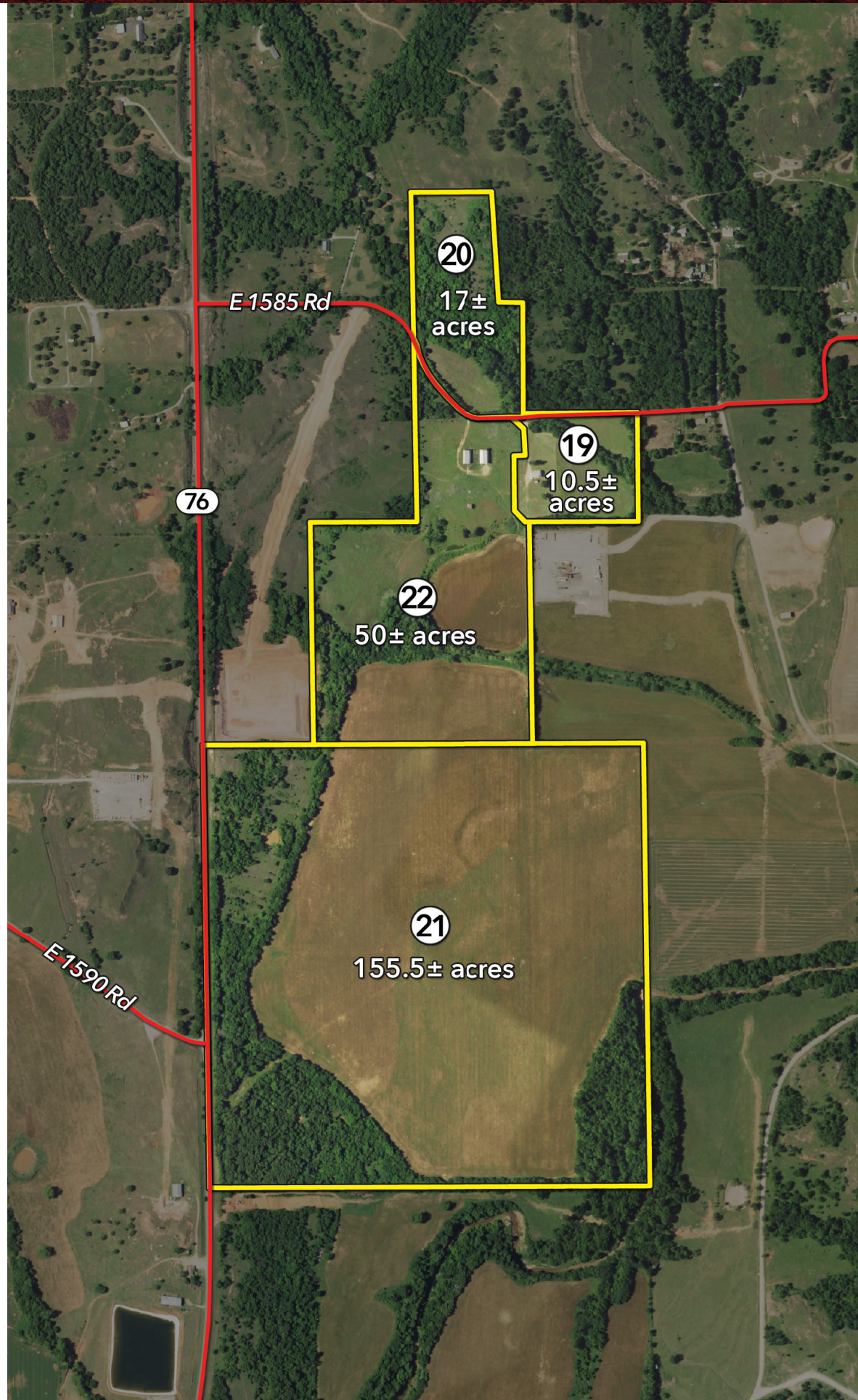

THURSDAY, JANUARY 31 • 1:00 PM

SOILS MAP

800.451.2709
SchraderAuction.com

 **SCHRADER**
Real Estate and Auction Company, Inc.

THURSDAY, JANUARY 31 • 1:00 PM

TOPOGRAPHY MAP

800.451.2709
SchraderAuction.com

 **SCHRADER**
Real Estate and Auction Company, Inc.

TOPOGRAPHY MAP

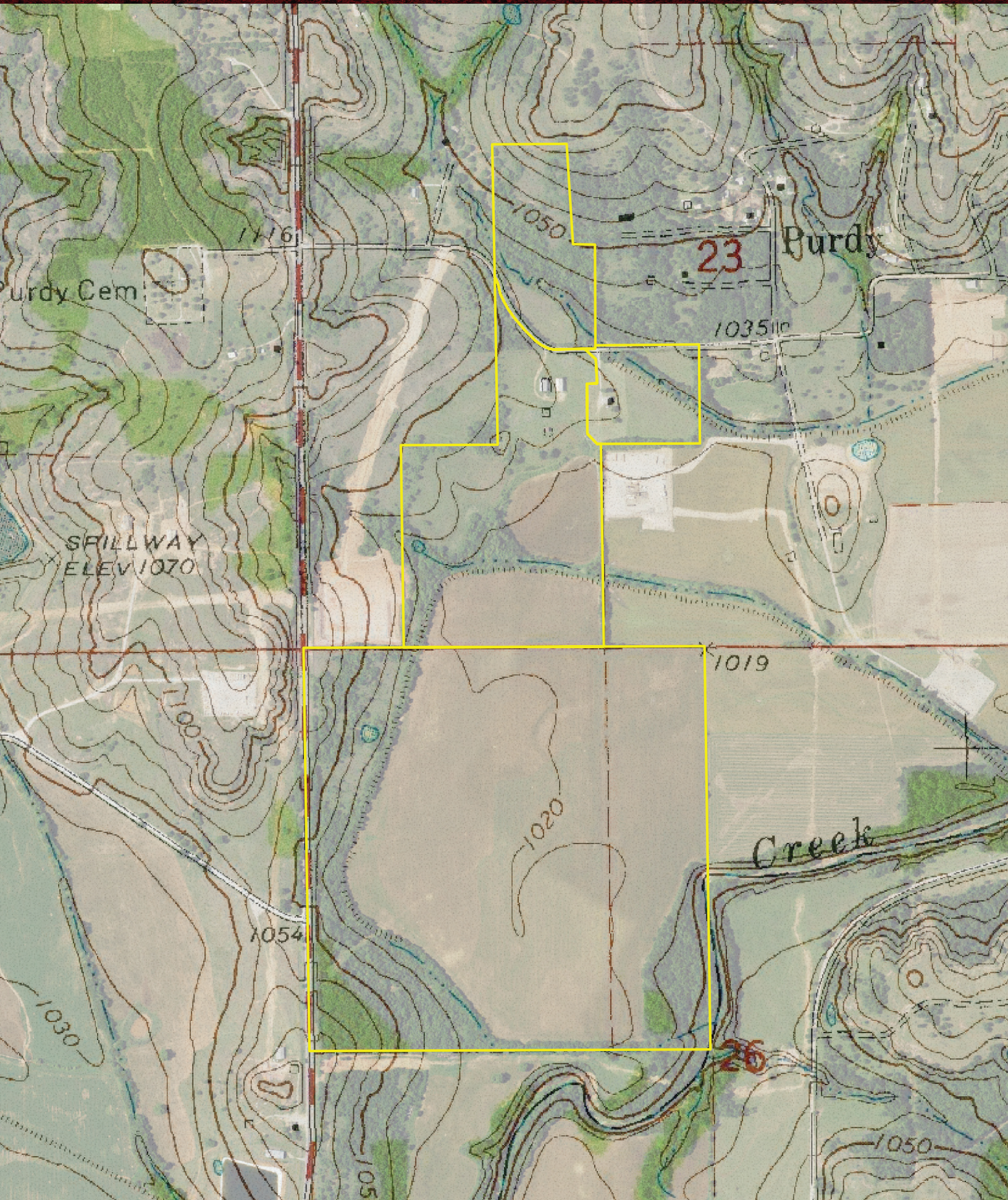

THURSDAY, JANUARY 31 • 1:00 PM

FLOOD ZONE MAP

800.451.2709
SchraderAuction.com

 **SCHRADER**
Real Estate and Auction Company, Inc.

FLOOD ZONE MAP

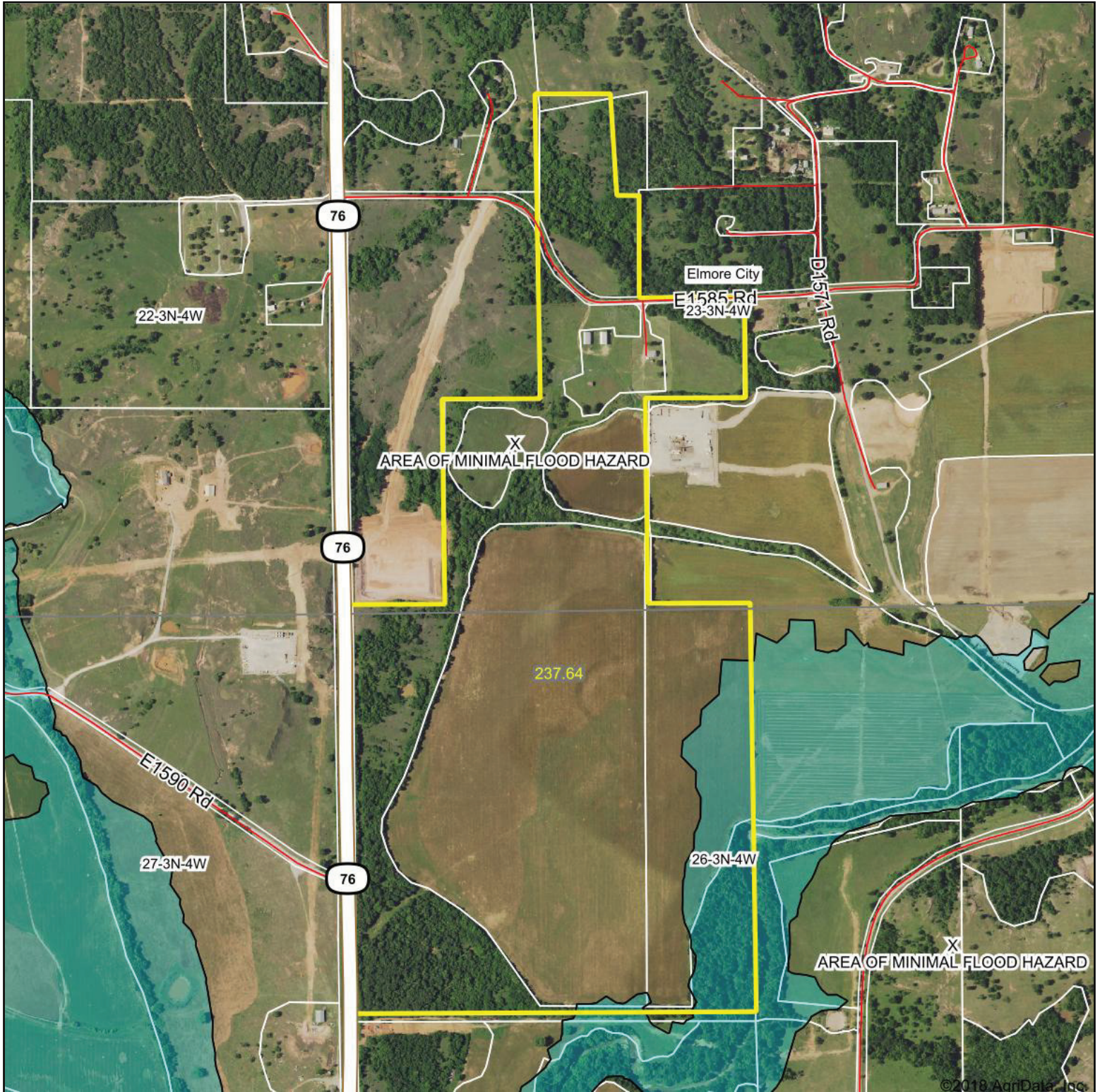

©2018 AgriData, Inc.



map center: 34° 42' 40.71, -97° 35' 37

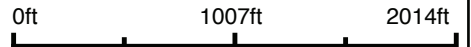

Maps Provided By:



23-3N-4W
Garvin County
Oklahoma

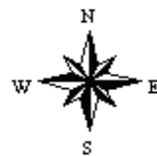

12/22/2018

THURSDAY, JANUARY 31 • 1:00 PM

TITLE COMMITMENT

800.451.2709
 **SchraderAuction.com**

 **SCHRADER**
Real Estate and Auction Company, Inc.

TITLE COMMITMENT

Cover page for:

Preliminary Title Insurance Schedules (with copies of recorded exceptions)

Preliminary title insurance schedules prepared by:

American Abstract Company of McClain County, Inc.

File Number: 20190035

Auction Tracts 19 - 22

(Surface Tracts Only)

Garvin County, State of Oklahoma

For auction conducted on January 31, 2019 by:

Schrader Real Estate and Auction Company, Inc.

On behalf of:

Mary and James Harrison Foundation

TITLE COMMITMENT

American Land Title Association

Commitment for Title Insurance
Adopted 08-01-2016

American Security Title Insurance Company

Transaction Identification Data for reference only:

Issuing Agent: American Abstract Company
Issuing Office: 138 West Main, Purcell, OK 73080
ALTA® Universal ID: 0002360
Loan ID Number:
Commitment Number: 20190035
Issuing Office File Number: 20190035
Property Address: , , OK

SCHEDULE A

1. Commitment Date: December 31, 2018 at 07:30 AM
2. Policy to be issued:
 - (a) ALTA Own. Policy (06/17/06)
Proposed Insured:
Proposed Policy Amount:
 - (b) ALTA Loan Policy (06/17/06)
Proposed Insured:
Proposed Policy Amount:
3. The estate or interest in the Land described or referred to in this Commitment is Fee Simple.
4. Title to the Fee Simple estate or interest in the Land is at the Commitment Date vested in:
Mary and James Harrison Foundation, by virtue of a Quit Claim Deed filed April 29, 2011 in Book 1942 at Page 597.
5. The Land is described as follows:
The West 7.5 acres of the SW $\frac{1}{4}$ SE $\frac{1}{4}$ NW $\frac{1}{4}$ and the E $\frac{1}{2}$ SW $\frac{1}{4}$ SW $\frac{1}{4}$ and the SE $\frac{1}{4}$ NE $\frac{1}{4}$ SW $\frac{1}{4}$ and the W $\frac{1}{2}$ E $\frac{1}{2}$ SW $\frac{1}{4}$ of Section 23, Township 3 North, Range 4 West of the I.B.M., Garvin County, Oklahoma
AND
The NW $\frac{1}{4}$ of Section 26, Township 3 North, Range 4 West of the I.B.M., Garvin County, Oklahoma.
LESS AND EXCEPT Beginning at the SW corner of said W $\frac{1}{2}$ NW $\frac{1}{4}$; thence East along the South line of said W $\frac{1}{2}$ NW $\frac{1}{4}$ a distance of 69.3 feet; thence N 0°04' W a distance of 2659.4 feet to a point on the North line of said W $\frac{1}{2}$ NW $\frac{1}{4}$; thence West along said North line a distance of 74 feet to the NW Corner of said W $\frac{1}{2}$ NW $\frac{1}{4}$; thence South along the West line of said W $\frac{1}{2}$ NW $\frac{1}{4}$ a distance of 2659.4 feet to point of beginning.

This page is only a part of a 2016 ALTA® Commitment for Title Insurance issued by American Security Title Insurance Company. This Commitment is not valid without the Notice; the Commitment to Issue Policy; the Commitment Conditions; Schedule A; Schedule B, Part I-Requirements; and Schedule B, Part II-Exceptions; and a counter-signature by the Company or its issuing agent that may be in electronic form.

Copyright 2006-2016 American Land Title Association. All rights reserved.
The use of this Form (or any derivative thereof) is restricted to ALTA licensees and ALTA members in good standing as of the date of use. All other uses are prohibited.
Reprinted under license from the American Land Title Association.



(20190035.PFD/20190035/4)

TITLE COMMITMENT

American Land Title Association

Commitment for Title Insurance
Adopted 08-01-2016

SCHEDULE A (Continued)

Date: January 9, 2019

American Abstract Company

By: _____

American Abstract Company of McClain County, Inc.,
Leona Gayle Helton #85561

This page is only a part of a 2016 ALTA® Commitment for Title Insurance issued by American Security Title Insurance Company. This Commitment is not valid without the Notice; the Commitment to Issue Policy; the Commitment Conditions; Schedule A; Schedule B, Part I-Requirements; and Schedule B, Part II-Exceptions; and a counter-signature by the Company or its issuing agent that may be in electronic form.

Copyright 2006-2016 American Land Title Association. All rights reserved.
The use of this Form (or any derivative thereof) is restricted to ALTA licensees and ALTA members in good standing as of the date of use. All other uses are prohibited.
Reprinted under license from the American Land Title Association.

AMERICAN
LAND TITLE
ASSOCIATION



TITLE COMMITMENT

American Land Title Association

Commitment for Title Insurance
Adopted 08-01-2016

American Security Title Insurance Company

SCHEDULE B, PART I Requirements

All of the following Requirements must be met:

1. The Proposed Insured must notify the Company in writing of the name of any party not referred to in this Commitment who will obtain an interest in the Land or who will make a loan on the Land. The Company may then make additional Requirements or Exceptions.
2. Pay the agreed amount for the estate or interest to be insured.
3. Pay the premiums, fees, and charges for the Policy to the Company.
4. Documents satisfactory to the Company that convey the Title or create the Mortgage to be insured, or both, must be properly authorized, executed, delivered, and recorded in the Public Records.
5. Return properly executed Buyer/Seller Statement to the Company, including satisfactory evidence that all bills for labor and materials furnished for the improvements of said premises have been or will be paid and item (a) of Schedule B-II, Standard Exceptions will not appear on policy.
6. Provide a satisfactory survey (or exception will remain), of the subject premises made in accordance with Minimum Standard Detail Requirements and Classifications for ALTA/ACSM Land Title Surveys (the Survey Standards) including, but not limited to, Items 8, 9, 10, 11 and 13 as set forth in Table A of the Survey Standards.
NOTE: Certain conditions or requirements of other parties to the transaction may require other items in Table A of the Survey Standards be included in the survey.
7. Obtain certification as to any unmatured special assessments and if any are found, have them paid in full. If certification is not obtained, an exception will be taken on policy.
8. Obtain final abstracting for issuance of title policy.
9. Final policy cannot be issued, unless abstract certificate date is no more than 180 days from the recording date of the instruments to be insured, or abstract must be extended to date, resulting in additional charges, before the final policy can be issued.
10. Obtain a Uniform Commercial Code search as to To be determined in Oklahoma County, and satisfy any judgments or liens which might affect the subject property and have releases thereof filed of record.
11. Obtain a court search as to May and James Harrison Foundation in Garvin County, and satisfy any judgments or liens which might affect the subject property and have releases thereof filed of record.
12. A review of the following documents prior to closing for May and James Harrison Foundation
 1. A Certificate of Good Standing from the state of domicile of the company and a Certificate of Authority to do business in Oklahoma.
 2. A certified copy of the executed Articles of Incorporation and ByLaws, and all amendments thereto.
 3. A copy of any other instruments appointing a President or Vice President;

This page is only a part of a 2016 ALTA® Commitment for Title Insurance issued by American Security Title Insurance Company. This Commitment is not valid without the Notice; the Commitment to Issue Policy; the Commitment Conditions; Schedule A; Schedule B, Part I-Requirements; and Schedule B, Part II-Exceptions; and a counter-signature by the Company or its issuing agent that may be in electronic form.

Copyright 2006-2016 American Land Title Association. All rights reserved.
The use of this Form (or any derivative thereof) is restricted to ALTA licensees and ALTA members in good standing as of the date of use. All other uses are prohibited.
Reprinted under license from the American Land Title Association.

AMERICAN
LAND TITLE
ASSOCIATION



(20190035.PFD/20190035/4)

TITLE COMMITMENT

American Land Title Association

Commitment for Title Insurance
Adopted 08-01-2016

SCHEDULE B (Continued)

SCHEDULE B, PART II Exceptions

THIS COMMITMENT DOES NOT REPUBLISH ANY COVENANT, CONDITION, RESTRICTION, OR LIMITATION CONTAINED IN ANY DOCUMENT REFERRED TO IN THIS COMMITMENT TO THE EXTENT THAT THE SPECIFIC COVENANT, CONDITION, RESTRICTION, OR LIMITATION VIOLATES STATE OR FEDERAL LAW BASED ON RACE, COLOR, RELIGION, SEX, SEXUAL ORIENTATION, GENDER IDENTITY, HANDICAP, FAMILIAL STATUS, OR NATIONAL ORIGIN.

The Policy will not insure against loss or damage resulting from the terms and provisions of any lease or easement identified in Schedule A, and will include the following Exceptions unless cleared to the satisfaction of the Company:

1. Any defect, lien, encumbrance, adverse claim, or other matter that appears for the first time in the Public Records or is created, attaches, or is disclosed between the Commitment Date and the date on which all of the Schedule B, Part I-Requirements are met.
2. Easements, liens or encumbrances or claims thereof, which are not shown by the public record.
3. Rights or claims of parties in possession not shown by the public records.
4. Encroachments, overlaps, discrepancies or conflicts in boundary lines, shortage in area, or other matters which would be disclosed by an accurate and complete survey or inspection of the premises.
5. Any lien, or right to a lien, for services, labor or material heretofore or hereafter furnished, imposed by law and not shown by the public records.
6. Real Estate taxes for 2019 and subsequent years, amount of which is not ascertainable, due or payable.
7. Any claim to (a) ownership of or rights to minerals and similar substances, including but not limited to ores, metals, coal, lignite, oil, gas, uranium, clay, rock, limestone, sand, and gravel located in, on, or under the Land or produced from the Land, whether such ownership or rights arise by lease, grant, exception, conveyance, reservation, or otherwise; and (b) any rights, privileges, immunities, rights of way, and easements associated therewith or appurtenant thereto, whether or not the interests or rights excepted in (a) or (b) appear in the Public Records.
8. Any regulation or use limitation imposed by the municipality.
9. Water rights, claims or title to water, whether or not shown by the public records.
10. Statutory easement for roadway along Section line.
11. Drainage Ditch filed November 22, 1946 in Book 264 at Page 600.
12. Right of Way Grant filed December 10, 1946 in Book 265 at Page 440.
13. Highway in favor of the State of Oklahoma filed May 7, 1954 in Book 409 at Page 11.

This page is only a part of a 2016 ALTA® Commitment for Title Insurance issued by American Security Title Insurance Company. This Commitment is not valid without the Notice; the Commitment to Issue Policy; the Commitment Conditions; Schedule A; Schedule B, Part I-Requirements; and Schedule B, Part II-Exceptions; and a counter-signature by the Company or its issuing agent that may be in electronic form.

Copyright 2006-2016 American Land Title Association. All rights reserved.
The use of this Form (or any derivative thereof) is restricted to ALTA licensees and ALTA members in good standing as of the date of use. All other uses are prohibited.
Reprinted under license from the American Land Title Association.



TITLE COMMITMENT

American Land Title Association

Commitment for Title Insurance
Adopted 08-01-2016

SCHEDULE B (Continued)

14. Right of Way filed July 21, 1954 in Book 414 at Page 342.
15. Right of Way filed December 6, 1954 in Book 425 at Page 232.
16. Right of Way filed August 16, 1956 in Book 481 at Page 71.
17. Easement filed October 20, 1959 in Book 557 at Page 99.
18. Right of Way Easement filed June 30, 2003 in Book 1693 at Page 812.
19. Order to annex rural water and/or sewer and/or gas and/or solidwaste management filed May 3, 2004 in Book 1697 at Page 311
20. Right of Way Easement filed June 20, 2005 in Book 1738 at Page 32.
21. Right of Way Easement filed August 9, 2005 in Book 1743 at Page 63.
22. Pipeline Easement filed September 4, 2012 in Book 1993 at Page 347.
23. Pipeline Easement filed October 6, 2017 in Book 2194 at Page 311.

This page is only a part of a 2016 ALTA® Commitment for Title Insurance issued by American Security Title Insurance Company. This Commitment is not valid without the Notice; the Commitment to Issue Policy; the Commitment Conditions; Schedule A; Schedule B, Part I-Requirements; and Schedule B, Part II-Exceptions; and a counter-signature by the Company or its issuing agent that may be in electronic form.

Copyright 2006-2016 American Land Title Association. All rights reserved.
The use of this Form (or any derivative thereof) is restricted to ALTA licensees and ALTA members in good standing as of the date of use. All other uses are prohibited.
Reprinted under license from the American Land Title Association.

AMERICAN
LAND TITLE
ASSOCIATION



(20190035.PFD/20190035/4)

TITLE COMMITMENT

EXCEPTIONS

#11

CONTRACT AND AGREEMENT

STATE OF OKLAHOMA
COUNTY OF GARVIN ss

This contract and agreement, made and entered into on this 21st day of November, 1946, by and between P. R. Williamson, hereinafter referred to as Party of the First Part, and Tennie Lee, hereinafter referred to as Party of the Second Part:

WITNESSETH: Whereas party of the first part is the owner of the following described lands and premises, to-wit:

SE $\frac{1}{4}$ of the NE $\frac{1}{4}$ of the SW $\frac{1}{4}$, and the W $\frac{1}{2}$ of the NE $\frac{1}{4}$ of the SW $\frac{1}{4}$, and the W $\frac{1}{2}$ of the SE $\frac{1}{4}$ of the SW $\frac{1}{4}$ of Section 23, Twp. 3-N, Range 4-W, I.M.

And whereas party of the second part is the owner of the following described lands and premises, to-wit:

NE $\frac{1}{4}$ of NE $\frac{1}{4}$ of SW $\frac{1}{4}$ and E $\frac{1}{2}$ of the SE $\frac{1}{4}$ of SW $\frac{1}{4}$ and SW $\frac{1}{4}$ of SE $\frac{1}{4}$ of Section 23, and the NW $\frac{1}{4}$ of NE $\frac{1}{4}$ of Section 26, Twp. 3-N, Range 4-W.

And whereas, there has heretofore been constructed a drainage ditch over and across the SE $\frac{1}{4}$ of the NE $\frac{1}{4}$ of the SW $\frac{1}{4}$ of said Section 23, which ditch enters said 10 acres last described at a point approximately 300 feet north of the southeast corner of said 10-acre tract last described and runs in a northwesterly direction across said ten acres to a point approximately 50 feet east of the northwest corner of said 10-acre tract;

And whereas there has heretofore been constructed a drainage ditch over and across the E $\frac{1}{2}$ of SE, SW $\frac{1}{4}$ and the SW of SE $\frac{1}{4}$ of Section 23, and the NW of the NE $\frac{1}{4}$ of Section 26, Twp. 3-N, Range 4-W, which said drainage ditch commences at a point on the west line of the E $\frac{1}{2}$ of the SE, SW $\frac{1}{4}$, approximately 400 feet north of the southwest corner of said last described 20-acre tract and running in a southeasterly direction to the right-a-way of State Highway 76;

And whereas certain differences have arisen between the parties hereto over the repair and maintenance of said drainage ditches, it is the desire of the parties hereto to settle, once and forever, said differences;

TITLE COMMITMENT

Page 2

NOW, THEREFORE, in consideration of the mutual covenants and agreements of the parties hereto, it is hereby mutually agreed by and between the parties hereto as follows, to-wit:

That the party of the second part, her heirs, administrators, and assigns, shall have the right at all times to repair and maintain the drainage ditch first hereinabove described and the levee just south and adjacent thereto, and the party of the first part does hereby grant to the party of the second part a perpetual easement over and across the said SE, NE, SW, of said Section 23, for the purpose of enabling the party of the second part, her heirs, and assigns, to repair and maintain said drainage ditch and levee, and the said party of the second part does hereby covenant and agree to keep and maintain said ditch and levee in good condition, such repair and maintenance to be at the expense of the party of the second part, her heirs and assigns.

That the party of the first part, his heirs, administrators, and assigns, shall have the right at all times to repair and maintain the drainage ditch last hereinabove described and the levees adjacent thereto, and the party of the second part does hereby grant to the party of the first part a perpetual easement over and across the said E $\frac{1}{2}$ of SE, SW, and the SW, SE of Section 23, and the NW, NE of Section 26, for the purpose of enabling the party of the first part, his heirs and assigns, to repair and maintain said drainage ditch and levees adjacent thereto, the levees to be constructed, maintained and repaired in accordance with the directions of the Soil Conservation Commission, and the said party of the first part does hereby covenant and agree to keep and maintain said ditch and levees in good condition, such repair and maintenance to be at the expense of the party of the first part, his heirs and assigns; and further, the said party of the first part covenants and agrees to fill up all holes or excavations along the west line of said E $\frac{1}{2}$, SE, SW, of Section 23.

IT IS FURTHER UNDERSTOOD AND AGREED that this contract shall extend to and be binding upon the heirs, executors, administrators and assigns of the parties hereto and that the covenants herein expressed shall run with the land.

WITNESS our hands the day and date first above written.

P. R. Williamson, Party of the First Part
Tennie Lee, Party of the Second Part

TITLE COMMITMENT

Page 3

STATE OF OKLAHOMA
COUNTY OF GARVIN SS

Before me, the undersigned, a Notary Public in and for said County and State, on this 21 day of November, 1946, personally appeared P. R. Williamson and Tennie Lee, to me known to be the identical persons who executed the within and foregoing instrument and acknowledged to me that they executed the same as their free and voluntary act and deed for the uses and purposes therein set forth.

Given under my hand and seal the day and year last above written.

(Seal)

My comm. Expires 1-17-49

J. L. Charles, Notary Public

FILED: Nov. 22, 1946 at 8 AM
RECORDED: Misc. 264, page 600

TITLE COMMITMENT

RIGHT OF WAY GRANT

KNOW ALL MEN BY THESE PRESENTS: That the undersigned, hereinafter called "Grantor" whether one or more, for and in consideration of Eighty One only (\$81.00) Dollars, cash in hand paid, receipt of which is hereby acknowledged, does hereby grant and convey unto INTERSTATE OIL PIPE LINE COMPANY a Delaware corporation hereinafter called "Grantee" its successors and assigns, a right of way and easement for the purpose of laying, maintaining, operating, patrolling (including aerial patrol) altering, repairing, renewing and removing in whole or in part a pipe line for the transportation of crude petroleum, its products and derivatives whether liquid or gaseous and/or mixtures thereof, together with the necessary fixtures, equipment and appurtenances, including telephone and telegraph lines, or either of them, with necessary poles, equipment, guy wires and anchors over, through, upon, under and across the following described land situated in Garvin County, State of Oklahoma, to-wit:

N $\frac{1}{2}$ NW $\frac{1}{4}$ Section 26, Township 3 N, Range 4 W

together with the right to clear the right of way and remove or trim trees and brush and remove other obstructions for a sufficient distance along both sides of said pipe line so as to prevent damage or interference with its efficient operation and patrol, and together with the right of ingress and egress to and from said right of way through and over said above described land for any and all purposes necessary to the exercise by Grantee of the rights herein granted. Grantor covenants with Grantee that he is the lawful owner of the aforesaid lands, that he has the right and authority to make this grant, and that he will forever warrant and defend the title thereto against all claims whatsoever. Said warranty however, shall be limited to a return of the consideration paid for this grant, including damages.

Grantee, its successors and assigns may at any time lay additional lines of pipe upon payment of like consideration for each additional line so laid and subject to the same conditions.

TO HAVE AND TO HOLD the said right of way or easement unto said INTERSTATE OIL PIPE LINE COMPANY, its successors and assigns.

The Grantee, by the acceptance hereof agrees to bury said pipe lines through cultivated land so that they will not interfere with the ordinary cultivation thereof and also to pay any damage to crops

TITLE COMMITMENT

Page 2

fences and timer which may arise from laying, maintaining and operating said lines. Said damage, if not mutually agreed upon, shall be ascertained and determined by three disinterested persons, one to be appointed by Grantor, one by Grantee, its successors and assigns, and the third by the two persons aforesaid; and the award of such three arbitrators or any two of them in writing shall be final and conclusive. The cost of such arbitration shall be borne equally by Grantor and Grantee.

The undersigned Grantor reserves the right to the full use and enjoyment of said premises except as the same may be necessary for the purposes herein granted; provided that said Grantor shall not erece over any line or lines of Grantee any improvement of a nature such as to interfere with the rights hereby granted.

This instrument shall be binding upon the heirs, executors, administrators, successors and assigns of the parties hereto.

EXECUTED THIS 4th day of December, 1946.

P. R. Williamson
Mary Williamson
Emma Zoe Williamson

STATE OF OKLAHOMA
COUNTY OF GARVIN SS

On this 4th day of Dec. A.D. 1946, before me, the undersigned, a Notary Public in and for the County and State aforesaid, personally appeared P. R. Williamson, Mary Williamson and Emma Zoe Williamson, to me personally known to be the identical persons who executed the within and foregoing instrument and acknowledged to me that they executed the same as their free and voluntary act and deed for the uses and purposes therein set forth.

Witness my hand and of ficial seal.

(SEAL)
My commission expires 3-30-1948

Cicero I. Murray, Notary Public

FILED: December 10, 1946 at 1 PM
RECORDED: Misc. 265, page 440

TITLE COMMITMENT

#13

Instrument: Dedication Deed
Filed: May 7, 1954 at 8 A. M.
Recorded: Book 409 at Page 11

KNOW ALL MEN BY THESE PRESENTS:

That Emma Zoe Williamson and Mary Williamson of Garvin County, State of Oklahoma, hereinafter called the Grantors (whether one or more), for and in consideration of the sum of One dollar and no/100----- (\$1.00) and other good, valuable and sufficient considerations, do hereby grant, bargain, sell, convey and dedicate unto the State of Oklahoma the following described lots or parcels of land for the purpose of establishing thereon a public highway or facilities necessary and incidental thereto, to-wit:

A strip, piece or parcel of land lying in the $W\frac{1}{2}$ $NW\frac{1}{4}$ of Section 26, T 3 N, R 4 W in Garvin County, Oklahoma, Said parcel of land being described by metes and bounds as follows:

Beginning at the SW corner of said $W\frac{1}{2}$ $NW\frac{1}{4}$, thence East along the South line of said $W\frac{1}{2}$ $NW\frac{1}{4}$ a distance of 69.3 feet, thence $N 0^{\circ}04' W$ a distance of 2659.4 feet to a point on the North line of said $W\frac{1}{2}$ $NW\frac{1}{4}$, thence West along said North line a distance of 74 feet to the NW corner of said $W\frac{1}{2}$ $NW\frac{1}{4}$, thence South along the West line of said $W\frac{1}{2}$ $NW\frac{1}{4}$ a distance of 2659.4 feet to point of beginning.

Containing 3.35 acres, more or less, of new right-of-way, the remaining area included in the above description being the 16.5 foot section line right-of-way.

For the same considerations hereinbefore recited, said Grantors hereby waive, relinquish and release any and all right, title or interest in and to the surface of the above granted and dedicated tract of land and the appurtenances thereunto belonging, including any and all dirt, rock, gravel, sand and other road building materials, reserving and excepting unto said Grantors the mineral rights therein; provided, however, that any explorations or development of said reserved mineral rights shall not directly or indirectly interfere with the use of said land for the purposes herein granted; and reserving unto said Grantors the right of ingress and egress to said public highway from the remaining lands of the Grantors.

To have and to hold said above described premises unto the said State of Oklahoma, free, clear and discharged from any and all claims of damages or injury that may be sustained directly or indirectly to the remaining lands of the Grantors by reason of the construction and maintenance of a public highway and all highway excavations, embankments,

TITLE COMMITMENT

Page 2 - Dedication Deed

structures, bridges, drains, sight distance or safety areas and other facilities that may now or hereafter be, in the discretion of the grantee, necessary for the construction and maintenance of a public highway and incidental facilities over, across or along the above described real estate; the supervision and control of said public highway to be in such municipality, county or other agency of the State of Oklahoma as has or may have jurisdiction thereof by the laws of the State of Oklahoma; and said State of Oklahoma, its officers, agents, contractors and employees are hereby granted free access to said property for the purpose of entering upon, constructing, maintaining or regulating the use of said public highway and incidental facilities.

Said Grantors hereby covenant and warrant that at the time of the delivery of these presents they are the owners in fee simple of the above described premises and that same are free and clear of all liens and claims whatsoever.

The undersigned Grantors hereby designate and appoint Mary Williamson as agent to execute the claim and receive the compensation herein named.

In witness whereof the Grantors herein named have hereunto set their hands and seals this the 8 day of April 1954.

Emma Zoe Williamson
Mary Williamson

Acknowledged on this 8th day of April, 1945, by Emma Zoe Williamson and Mary Williamson, before George Davenport, a Notary Public in and for Garvin County, Oklahoma, whose commission expires: 2-1-58.
(Seal Affixed)

TITLE COMMITMENT

#14

Instrument: Right of Way
Filed: July 21, 1954 at 1 P. M.
Recorded: Book 414 at Page 342

THE STATE OF OKLAHOMA)
County of Garvin)

KNOW ALL MEN BY THESE PRESENTS: THAT

FOR AND IN CONSIDERATION of Ninety Nine and 50/100 DOLLARS to us paid, the receipt of which is hereby acknowledged, Mary Williamson and Emma Zoe Williamson, as partners, of Lindsay, Oklahoma, do hereby grant and convey to MAGNOLIA PIPE LINE COMPANY, a corporation organized under the laws of the State of Texas, with its principal office at Dallas, Texas, having a permit to do business in the State of Oklahoma, its successors and assigns, the rights of way, easements and privileges to lay, repair, maintain, operate and remove pipe lines and replace existing lines with other lines, for the transportation of oil and gas, and the products thereof, water, or any other fluid or substance, together with such drips, valves, fittings, meters, and similar appurtenances as may be necessary or convenient to the operation of said lines, and to erect, repair, maintain, remove and operate electric lines, graphite and steel anodes and other devices for the control of pipe line corrosion, over, across and through Grantors lands situated in the County of Garvin, and the State of Oklahoma, described as follows, to-wit:

S/2 of NE/4 of SW/4, Section 23, Township 3 North, Range 4 West,
W/2 of NE/4 of SW/4, Section 23, Township 3 North, Range 4 West,
The West 7.50 acres of SW/4 of SE/4 of NW/4, Section 23, Township
3 North, Range 4 West;

with ingress and egress to and from the same.

TO HAVE AND TO HOLD unto said Magnolia Pipe Line Company, its successors and assigns, so long as such line or lines shall be maintained for the purpose of constructing, inspecting, repairing, operating and maintaining the same and the removal of such at will, in whole or in part. The said Grantors to fully use and enjoy the said premises, except for the purposes hereinbefore granted to said Magnolia Pipe Line Company who hereby agrees to pay any damages which may arise to crops, timber and fences from the laying, erecting, maintaining and operating of said pipe, telegraph, telephone and electric lines; said damages if not mutually agreed upon to be ascertained and determined by three disinterested persons, one thereof to be appointed by the said Grantors, their heirs or assigns; one by Magnolia Pipe Line Company, or its assigns; and the third by the two so appointed as aforesaid, and the written award of such three persons, shall be final and conclusive. It is further agreed that said pipes shall be buried to a sufficient depth so as not to interfere with cultivation of soil.

TITLE COMMITMENT

Page 2 - Right of Way

The rights of way, easements and privileges herein granted are each divisible and are each assignable or transferable, in whole or in part.

It is hereby understood that party securing this grant in behalf of Grantee is without authority to make any covenant or agreement not herein expressed.

The above described property constitutes no portion of our homestead.

Witness our hands, this 12th day of April, 1954.

Signed and delivered in the presence of the undersigned witnesses:

Witnesses:	Mary Williamson
W. D. Mobley	Emma Zoe Williamson

STATE OF OKLAHOMA)
County of Garvin) ss:

On this 12th day of April, 1954, before me, the undersigned, a Notary Public in and for the County and State aforesaid, personally appeared Mary Williamson and Emma Zoe Williamson, to me personally known to be the identical persons who executed the within and foregoing instrument and acknowledged to me that they executed the same as their free and voluntary act and deed for the uses and purposes therein set forth.

(SEAL)	R. A. McMurtray, Notary Public
--------	-----------------------------------

My commission expires:
11-15-1955

TITLE COMMITMENT

#15

Instrument: Right of Way
Filed: Dec. 6, 1954 at 8 A. M.
Recorded: Book 425 at Page 232

FOR AND IN CONSIDERATION OF THE SUM OF (\$ 10.00) Ten and
no/100----- DOLLARS
to the grantors paid, the receipt of which is hereby acknowledged,
J. C. Donhan

herein called Grantors, hereby grant unto the following named Grantees,
the right to lay, maintain, inspect, operate, repair, replace and
remove Gas pipe line

for the transportation of crude petroleum, oil, gas, the products
or by-products of each thereof and also water, and further the right
to erect, install, maintain, inspect, operate, repair and remove
telegraph and telephone lines and equipment and apparatus therefor,
if grantees desire to do so, to be used in connection with any pipe
line owned by said Grantees, on, over and through the following-
described land, of which Grantors warrant they are the owners in fee
simple, situated in Garvin County, State of Oklahoma, to-wit:

SW SW NW Sec. 26 3N-4W

with the right of ingress and egress on, over and through said land
for any and all purposes necessary and incident to the exercise by
said Grantee of the rights granted hereunder, including, but not
limited to, the right to construct, operate and maintain a drip or
drips and a pit or pits for the purpose of draining off and burning,
or otherwise disposing of, waste products from said pipe line.

The said Grantees, and the proportions in which they shall own
the interest created hereby, are as follow:

Warren Petroleum Corporation-an undivided twenty-one percent (21%)
Kerr-McGee Oil Industries, Inc.-an undivided five percent (5%)
Oklahoma Natural Gas Co.-an undivided twenty-six percent (26%)
Cities Service Oil Company-an undivided twenty-three percent (23%)
The Texas Company-an undivided twenty-five percent (25%)

The said Grantors have the right to fully use and enjoy the said
premises except as the same may be necessary for the purposes herein
granted to the said Grantees. Any pipe line laid hereunder shall be
buried so it will not interfere with the cultivation of the surface
of said premises.

TITLE COMMITMENT

Page 2- Right of Way.

Grantees hereby agree to pay any damages which may arise from Grantees' operations in laying, maintaining, operating, repairing, replacing, or removing said pipe line. In the event parties cannot agree upon the amount of said damages, then the amount thereof shall be ascertained and determined by three disinterested persons selected as follows: One by said Grantors, one by said Grantees and the third by the two so selected, and the written award of said three persons so selected shall be final and conclusive on the parties hereto.

And for an additional consideration of One Dollar (\$1.00), the receipt of which is hereby acknowledged, said Grantors hereby grant unto said Grantees the right at any time to lay, maintain, inspect, operate, repair, replace, and remove an additional pipe line or pipe lines alongside of said first pipe line for the transportation of crude petroleum, oil, gas, the products or by-products of each thereof, and also water, on, over and through said land, said interest to be owned in the same proportions set forth above, and Grantees agree to pay Grantors for each additional pipe line placed on said land by it, at the rate of --- per rod, said payment to be made on or before the time Grantees commence to construct such pipe line on, over and through said land, said additional line or lines to be laid subject to the same rights, privileges and conditions as the original line.

Grantees have the right to change the size of their pipes, the damages, if any, in making such change to be paid by the said Grantees.

It is agreed that any payment hereunder may be made direct to said Grantors or any of them, or by depositing such payment to the credit of such Grantors or any one of them in the -----

----- Bank at -----
and payment so made shall be deemed and considered as payment to each of said Grantors; and that the terms, conditions and provisions of this contract shall extend to and be binding upon the heirs, executors, administrators, personal representatives, successors and assigns of the parties hereto.

IN TESTIMONY WHEREOF, witness my hand on this the 14th day of Nov., 1954.

J. C. Donham.

Acknowledged on this 14th day of November, 1954, by J. C. Donham, before Ruth D. Heath, a Notary Public in and for Garvin County, Oklahoma, whose commission expires: 1-17-56. (Seal Affixed)

TITLE COMMITMENT

#16

Instrument: Right of Way
Filed: August 16, 1956 at 1 P. M.
Recorded: Book 481 at Page 71

For and in consideration of the sum of Eighty-Seven and No/100--- Dollars (\$87.00) to us in hand paid, receipt of which is hereby acknowledged We, Mary and Emma Zoe Williamson do hereby grant, convey and warrant to Cherokee Pipe Line Company its successors and assigns, a Right-of-Way to construct, reconstruct, renew, operate, maintain, inspect, alter, repair and remove a pipe line, and such drips, valves, fittings, meters and other equipment and appurtenances as may be necessary or convenient for such operations, over, and through the following real estate in Garvin County, State of Oklahoma, to-wit:

87 Rods Right-Of-Way for a 2" crude oil pipe line across the NW¹/₄ Section 26-T3N-R4W (Five Rods) and across the E¹/₂ SW¹/₄ of the SW¹/₄ Section 23-T3N-R4W (82 Rods), (Line laid to connect The Superior Oil Company-Shelton Lease).

TO HAVE AND TO HOLD the same unto said Grantee, its successors and assigns, until said easement be exercised, and so long as any structure installed hereunder is used or remain thereon.

GRANTEE shall pay reasonable damages to growing crops, land fences or improvements occasioned in laying, operating, repairing or removing all lines, drips and valves. If the amount of damages be not agreed upon, it shall be determined by three disinterested persons, one appointed by the GRANTOR, one by the GRANTEE, and the third by the two so appointed, and their written determination of amount shall be final and conclusive. GRANTEE shall bury pipelines below plow depth.

It is understood that the person securing this grant is without authority from Grantee to make any agreement in respect of the subject matter hereof not herein expressed.

The grantors represent that the above described land is rented for the period beginning 19-- , to 19-- on-Basis.

Executed this 11 day of April, 1956.

Mary Williamson
Emma Zoe Williamson

Acknowledged on this 11th day of April, 1956, by Mary Williamson and Emma Zoe Williamson, before J. L. Charles, a Notary Public in and for Garvin County, Oklahoma, whose commission expires: Jan. 17, 1957.
(Seal Affixed)

TITLE COMMITMENT

#17

Instrument: Easement
Filed: October 20, 1959 at 3 P. M.
Recorded: Book 557 at Page 99

THE STATE OF OKLAHOMA }
COUNTY OF GARVIN }

KNOW ALL MEN BY THESE PRESENTS:

That the undersigned, in consideration of the sum of FIVE DOLLARS (\$5.00) in hand paid by THE SOUTHWESTERN STATES TELEPHONE CO., a Corporation, and the further consideration of the benefits and advantages accruing to the community from the erection and maintenance of telegraph and telephone lines across the lands and premises hereinafter mentioned, hereby grant unto the said THE SOUTHWESTERN STATES TELEPHONE CO., its successors and assigns, the right, privilege and authority to construct, operate and maintain its lines of telegraph and telephone, including the necessary poles, fixtures, guys, and brace poles, upon and over the property owned by the undersigned for a period of 99 years in Garvin County, State of Oklahoma; as follows:

NW $\frac{1}{4}$ NE $\frac{1}{4}$ SW $\frac{1}{4}$ Section 23 Township 3 North Range 4 West

And the said company shall have the right of ingress and egress at all times, and the right to pass through any fields upon said property when necessary to do so in order to build, repair, reconstruct or in any way improve and maintain said telephone and telegraph lines, wires and poles. But the said company shall at one replace and repair in as good condition as before, any fence removed, and pay all damages that may be caused to crops on said lands, by any negligence on its part in such use of said property. Said company shall also have the right to trim out of the way trees and brush that may be necessary in order to maintain said telephone and telegraph lines, or either of the same.

WITNESS this 24th day of June A. D., 1959

Mary Williamson
Emma Zoe Williamson

Acknowledged on this 24th day of June 1959 by Mary Williamson and Emma Zoe Williamson, before Kathern Williams, a Notary Public in and for Garvin County, Oklahoma whose commission expires: Feb. 25, 1962.
(Seal Affixed)

TITLE COMMITMENT

BOOK 1693 PAGE 813

STATE OF TEXAS
COUNTY OF [unclear]

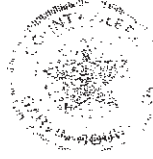

NOV 10 1993
1693 A
Dina Chandia

1693-812

1693-812

TITLE COMMITMENT

#19

I-2004-003362 Book 1697 Pg: 311
05/03/2004 11:22 am Pg 0311-0318
Fee: \$ 0.00 Doc: \$ 0.00
Gina Mann - Garvin County Clerk
State of Oklahoma

BEFORE THE BOARD OF COUNTY COMMISSIONERS OF GARVIN COUNTY

STATE OF OKLAHOMA

IN THE MATTER OF THE PETITION FOR THE)
ANNEXATION OF ADDITIONAL TERRITORY)
TO RURAL WATER and/or SEWER and/or)
GAS and/or SOLID WASTE MANAGEMENT)
DISTRICT NO. 5, STEPHENS COUNTY,)
OKLAHOMA.)

Stephens Co
NO.RWD#5

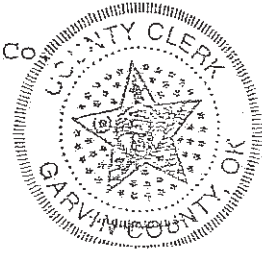

ORDER ANNEXING ADDITIONAL TERRITORY TO RURAL WATER AND/OR
SEWER AND/OR GAS AND/OR SOLID WASTE MANAGEMENT DISTRICT
NO. 5, STEPHENS COUNTY, OKLAHOMA

NOW on this 3rd day of May, 2004, comes regularly on for hearing the Petition to Annex Additional Territory to Rural Water and/or Sewer and/or Gas and/or Solid Waste Management District No. 5, Stephens County, Oklahoma, filed with the County Clerk of Garvin County, Oklahoma, on April 7, 2004, praying for the annexation of additional territory to said District as described and set forth with more particularity in said Petition.

The Petitioners appeared in person, along with Rural Water District No. 5 representatives and their attorney, ROBERT J. HAYS of HAYS & GORDON, and no protestant appeared.

The Board of County Commissioners of Garvin County, Oklahoma, having considered the Petition for Annexation of Additional Territory, which was filed herein and having heard statements of counsel and representatives of the Petitioners, FINDS:

1. That proper notice of the time and place of the hearing have been given as required by 82 O.S. § 1324.5; that the County Clerk on the 8th day of April, 2004, caused Notices of the hearing to be mailed by certified mail to each of the Petitioners,

TITLE COMMITMENT

I-2004-003362 Book 1697 Pg: 312
05/03/2004 11:22 am Pg 0311-0318
Fee: \$ 0.00 Doc: \$ 0.00
Gina Mann - Garvin County Clerk
State of Oklahoma

a copy of aforesaid Notice being attached hereto and made a part hereof; that the County Clerk caused the Notice of Hearing aforesaid to be published for two (2) consecutive weeks on April 15, 2004, and April 22, 2004, in the Lindsay News, a newspaper of general circulation in Garvin County, Oklahoma; that the property prayed to be annexed is all located in Garvin County, Oklahoma, and that the Clerk has duly filed with this Board her Proof of Mailing Notice and Publication of Hearing, together with the Publisher's Affidavit of Publication.

2. That the lands within the proposed annexation are located in Garvin County, and that this Board has jurisdiction to hear and determine the Petition and order said property annexed to the District.

3. That the Petitioners are owners of land within the boundaries of the proposed annexed territory to Rural Water and/or Sewer and/or Gas and/or Solid Waste Management District No. 5, Stephens County, Oklahoma, and as such landowners are qualified to Petition this Board for the Annexation of said property to said District.

4. That the rural residents of the area are embraced within the area to be annexed as described in the Petition and are without an adequate water supply or sewage facilities or gas distribution facilities or solid waste management system to meet their needs; and that the Oklahoma Water Resources Board has certified that there is water available to adequately serve the proposed District.

TITLE COMMITMENT

12004-003362 Book 1697 Pg: 313
05/03/2004 11:22 am Pg 0311-0318
Fee: \$ 0.00 Doc: \$ 0.00
Gina Mann - Garvin County Clerk
State of Oklahoma

5. That the construction, installation improvements, maintenance and operation of all or any combination of water works, sewage facilities, gas distribution facilities and solid waste management facilities are necessary to provide an adequate water supply, sewage facility, gas distribution facilities and solid waste management system to serve rural residents of the proposed annexed area. That such improvements or works will be conducive to and will promote the public health convenience and welfare.

6. That the Petition filed herein is in conformity with the requirements of the Rural Water, Sewer, Gas and Solid Waste Management Districts Act.

IT IS THEREFORE ORDERED, ADJUDGED, DECREED and DECLARED by the Board of County Commissioners of Garvin County, Oklahoma, that the lands hereinafter described be, and the same are hereby, annexed to Rural Water and/or Sewer and/or Gas and/or Solid Waste Management District No. 5, Stephens County, Oklahoma, said lands being described with more particularity as follows:

All of Sections 19, 20, 29, 30, 31 and 32 of Township 4 North, Range 4 West of I.M.;

The West Half (W/2) of Section 21, Township 4 North, Range 4 West of I.M.;

The West Half (W/2) of Section 28, Township 4 North, Range 4 West of I.M.;

The West Half (W/2) of Section 33, Township 4 North, Range 4 West of I.M.;

The West Half (W/2); and the South Half of Southwest Quarter of Southeast Quarter (S/2 SW/4 SE/4) of Section 3, Township 3 North, Range 4 West of I.M.;

TITLE COMMITMENT

1-2004-003362 Book 1697 Pg: 314
05/03/2004 11:22 am Pg 0311-0318
Fee: \$ 0.00 Doc: \$ 0.00
Gina Mann - Garvin County Clerk
State of Oklahoma

All of Sections, 4, 5, 6, 7, 8, 9, 10, 12, 13, 14, 15, 16, 17, 18, 19, 20, 21, 22, 23, 24, 25, 26, 27, 28, 29, 30, 31, 32, 33, 34, 35 and 36 in Township 3 North, Range 4 West of I.M.;

The South Half of Southeast Quarter (S/2 SE/4); and a parcel of land entirely within the Northeast Quarter of Southeast Quarter (NE/4 SE/4) of Section 2, Township 3 North, Range 4 West of I.M., and more particularly described as: Commencing at the Southeast corner of said Section 2, thence North along the East section line a distance of 1,320 feet to the point of beginning, thence North along the East section line, a distance of 1,065 feet, thence Southwest at a bearing of South 41°12'26" West a distance of 1,435 feet, thence East along the 16th section line a distance of 946.5 feet to the point of beginning, containing 11.57 acres, more or less;

The South Half (S/2); and the South Half of South Half of Northwest Quarter (S/2 S/2 NW/4); and the South Half of South Half of Northeast Quarter (S/2 S/2 NE/4); and Northeast Quarter of Southeast Quarter of Northeast Quarter (NE/4 SE/4 NE/4); and the East Half of Northeast Quarter of Northeast Quarter (E/2 NE/4 NE/4) of Section 1, Township 3 North, Range 4 West of the I.M.;

The Northeast Quarter (NE/4); and the South Half (S/2) of Section 11, Township 3 North, Range 4 West of I.M.;

All of Section 32, Township 4 North, Range 3 West of I.M.;

All of Sections 5, 7 and 8 in Township 3 North, Range 3 West of I.M.;

All of Section 6, Township 3 North, Range 3 West of the I.M., LESS AND EXCEPT the Northwest Quarter of Northwest Quarter of Northwest Quarter (NW/4 NW/4 NW/4);

All of Sections 15, 16, 17, 18, 19, 20, 21, 22, 26, 27, 28, 29, 30, 31, 32, 33, 34 and 35 in Township 3 North, Range 3 West of I.M.;

TITLE COMMITMENT

1-2004-003362 Book 1697 Pg: 315
05/03/2004 11:22 am Pg 0311-0318
Fee: \$ 0.00 Doc: \$ 0.00
Gina Mann - Garvin County Clerk
State of Oklahoma

All of Sections 2, 3, 4, 5, 6, 7, 8, 9, 10,
11, 14, 15, 16, 17, 18, 19, 20, 21, 22, 23,
24, 25, 26, 27, 28, 29, 30, 31, 32, 33, 34, 35
and 36 in Township 2 North, Range 3 West of
I.M.;

All of Sections 1, 2, 3, 4, 5, 6, 7, 8, 9, 10,
11, 12, 18, 19, 30 and 31 in Township 1 North,
Range 3 West of I.M.;

All of Sections 31 and 32 in Township 2 North,
Range 2 West of I.M.;

All of Sections 5, 6, 7 and 8 in Township 1
North, Range 2 West of I.M.

BOARD OF COUNTY COMMISSIONERS
GARVIN COUNTY, OKLAHOMA

KENNETH HOLDEN

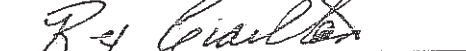
REX CARLTON

JOHNNY MANN

TITLE COMMITMENT

22

PIPELINE EASEMENT

Return To: Rodney Eischen
Oneok Field Services
15006 HWY 19
Tulsa, OK 73050

GRANTOR: MARY AND JAMES HARRISON FOUNDATION

whose address is:

c/o BOKF, NA, dba Bank of Oklahoma
Trust Real Estate
9520 N. May, Second Floor
Oklahoma City, OK 73120

GRANTEE:

whose address is:

ONEOK Field Services Company, L.L.C
P.O. Box 871
Tulsa, OK. 74102-0871

EASEMENT TRACT:

A 30-foot wide strip of land being 187 rods in length in the NW/4 Section 26, T3N-R4W, I.M., Garvin County, OK, the centerline of which is specifically described as " Proposed ONEOK 12" " on the attached survey plat marked Exhibit "A" attached hereto and made a part hereof.

INSTALLATION PERIOD: One Hundred Eighty (180) days.

The undersigned Grantor, for good and valuable consideration, the receipt and sufficiency of which is hereby acknowledged, does hereby grant and convey unto Grantee, a **non-exclusive** easement to enter, construct, operate, repair, replace and maintain on the Easement Tract a single 12-inch pipeline to be installed at a minimum depth of 48 inches (the "Pipeline") to be used exclusively for the transportation of oil and/or gas and all associated by products. Grantee has also executed this instrument to evidence its agreement to all of the terms and provisions hereof.

In connection with the foregoing grant, Grantor and Grantee further agree as follows:

1. Grantor may continue to use and enjoy the Easement Tract in any manner which does not unreasonably interfere with Grantee's use of the Easement Tract for the purposes described above. If any portion of the Easement Tract is used for ingress and/or egress whether now or in the future by Grantor, its lessees, or their respective successors or assigns, Grantee will ensure that its activities do not prevent or otherwise adversely affect such ingress and egress.

1-2012-007948 Book 1993 Pg. 347
09/04/2012 8:00 am Pg 0347-0354
Fee: \$ 27.00 Doc \$ 0.00
Lori Fulks - Garvin County Clerk
State of Oklahoma



Pg 347 B
BOKF
LH

TITLE COMMITMENT

will be disturbed without Grantor's prior written consent and, to the extent such consent is given, any damaged improvements will be promptly repaired by Grantee in a good and workmanlike manner. Grantee agrees to maintain the security associated with the premises, including, without limitation, containing any livestock.

3. If necessary for the installation, operation, or maintenance of the Pipeline, Grantee may remove any crops or grasses from the Easement Tract and in such event, Grantee shall pay the reasonable value of any crops or vegetation removed or damaged promptly following said activities. After the installation of (or any repairs to) the Pipeline, Grantee shall repair any damage to the Easement Tract caused by such activities promptly following the completion of such activities (including but not limited to the reasonable restoration of the surface of any affected land), it being the parties' intent that Grantee will take any and all actions necessary, and pay any and all costs necessary, to cause the condition of the surface of the Easement Tract to be substantially the same as the condition that existed on the date hereof. If after the restoration of the soil to substantially the same condition as existed prior to such installation or repair there is excess soil, rock or other materials (collectively "Excess Materials"), Grantee shall own and shall remove any Excess Materials from the Easement Tract without any further compensation to Grantor (unless the Excess Materials have readily ascertainable market value, in which event Grantee shall have the right to either (a) leave the Excess Materials on site and disclaim any rights thereto, or (b) pay Grantor the fair market value thereof, less the Grantee's removal costs).

4. During the Installation Period, Grantee may enter upon and use an additional twenty-five (25) feet adjoining the Easement tract ("Construction Area") to the extent reasonably necessary in connection with the installation of the Pipeline. Grantee shall repair any damage caused by the activities of Grantee on any part of any Construction Area promptly following the completion of those activities (including but not limited to the reasonable restoration of the surface of any affected land), it being the parties' intent that Grantee will take any and all actions necessary, and pay any and all costs necessary, to cause the condition of the Construction Area to be substantially the same as the condition that existed on the date hereof. Grantee shall have no surface rights after the initial installation of the Pipeline is completed, except for (i) periodic maintenance and repair work and related activities, and (ii) signage which identifies the location of the Pipeline including but not limited to at each fence line crossed.

5. Grantor will not be required to provide any title materials and Grantee will complete its own title inspections. Grantee's rights hereunder are expressly made subject to any and all third party rights, including both surface and subsurface rights. Likewise, Grantee shall be responsible for obtaining any and all third party consents necessary in connection with this instrument (including consents by Tenants, if any), and Grantee shall pay any and all costs, expenses or damages incurred by any Tenant or other third party as the result of Grantee's violation of the terms of this instrument ("Third Party Claims").

6. Grantee and its successors and assigns will indemnify Grantor, its heirs, successors, and assigns from and against all claims, injuries, suits, damages, costs, losses, and reasonable expenses resulting from or arising out of Third-Party Claims and/or arising out of any of the actions of Grantee and/or its employees, agents and/or other representatives, or any of their respective successors and assigns, including, without limitation, the laying, maintenance, removal, repair, use or existence of the Pipeline.

7. The terms, conditions, and provisions of this Agreement shall extend to and be binding upon the heirs, devisees, executors, administrators, successors and permitted assigns of Grantor and Grantee; provided, however, that if Grantee fails to install the Pipeline before the end of the Installation Period, or fails to utilize the Pipeline for any full twelve (12) month period after installation is completed, this Agreement shall terminate and Grantee, its successors and assigns, will have no further rights hereunder.

8. Grantor is acting as a fiduciary and is executing this instrument strictly in its fiduciary capacity, and Grantor shall have no liability whatsoever in its separate corporate and/or individual capacity on any agreement, covenant or representation contained in this instrument. Notwithstanding anything contained herein, Grantor makes no warranties, either expressed or implied, regarding the

1-2012-007948 Book 1993 Pg. 348
09/04/2012 8:00 am Pg 0347-0354
Fee: \$ 27.00 Doc: \$ 0.00
Lon Fuiks - Carwin County Clerk
State of Oklahoma

Pg 2 of 8
billed
m

TITLE COMMITMENT

Easement Tract. All consideration received by Grantor will be fully earned upon receipt and will not be refundable under any circumstances.

9. This instrument may be executed in counterparts, any one of which need not contain the signatures of more than one party, but all such counterparts taken together shall constitute one and the same instrument.

Executed this 12 day of July, 2012.

GRANTOR:

Rusty Harrison – Co Trustee

Robert Harrison – Co Trustee

David Harrison – Co Trustee

John Harrison – Co Trustee

GRANTEE:

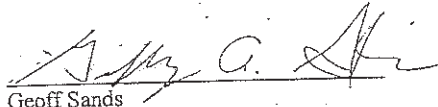

Geoff Sands

Vice President Natural Gas G&P Operations

1-2012-007948 Book 1993 Pg 349
06/04/2012 8:00 am Pg 0347-0354
Fee: \$ 27.00 Doc \$ 0.00
Lori Fuks - Garvin County Clerk
State of Oklahoma

Pg 378
Book DB

00-23

TITLE COMMITMENT

9. This instrument may be executed in counterparts, any one of which need not contain the signatures of more than one party, but all such counterparts taken together shall constitute one and the same instrument.

Executed this 12 day of July, 2012.

GRANTOR:

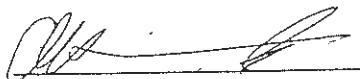

Rusty Harrison - Co Trustee
aka Charles W. Harrison



Robert Harrison - Co Trustee

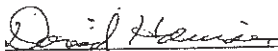

David Harrison - Co Trustee

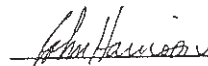

John Harrison - Co Trustee

GRANTEE:

Geoff Sands

Vice President Natural Gas G&P Operations

1-2012-007948 Book 1993 Pg 351
09/04/2012 8:00 am Pg 0347-0354
Fee: \$ 27 00 Doc \$ 0 00
Lon Fulk - Garvin County Clerk
State of Oklahoma

A9 538
BOKER

TITLE COMMITMENT

ACKNOWLEDGMENT

STATE OF OKLAHOMA)

COUNTY OF Garvin)

SS:

This instrument was acknowledged before me on July 12th, 2012, by

Jedon Harrison

My Commission Expires: 10-12-15

Loretta Elmore
Notary Public

99016016
Commission No.

ACKNOWLEDGMENT

STATE OF OKLAHOMA)

COUNTY OF Garvin)

SS:

This instrument was acknowledged before me on July 12th, 2012, by

Robert Harrison

My Commission Expires: 10-12-15

Loretta Elmore
Notary Public

99016016
Commission No.



1-2012-007948 Book 1993 Pg: 352
09/04/2012 8:00 am Pg:0347-0354
Fee \$ 27.00 Doc \$ 0.00
Lori Fulks - Garvin County Clerk
State of Oklahoma

Pg 628
LHF
M

TITLE COMMITMENT

ACKNOWLEDGMENT

STATE OF OKLAHOMA)
COUNTY OF Harvin) SS:

This instrument was acknowledged before me on July 12th, 2012, by
David Harrison

My Commission Expires: 10-12-15

Loretta Elmore
Notary Public

99016016
Commission No.

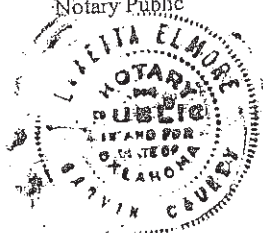

ACKNOWLEDGMENT

STATE OF OKLAHOMA)
COUNTY OF Cleveland) SS:

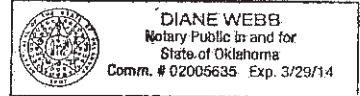

This instrument was acknowledged before me on July 12, 2012, by
Charles W. Harrison, Jr.

My Commission Expires: 3/29/14

Diane Webb
Notary Public

02005635
Commission No.

1-2012-007948 Book 1983 Pg. 353
09/04/2012 8:00 am Pg 0347-0354
Fee \$ 27 00 Doc \$ 0 00
Lori Fuks - Garvin County Clerk
State of Oklahoma

A9788
BOOK
M

TITLE COMMITMENT

#23

PIPELINE EASEMENT

GRANTOR: JOHN HARRISON, CHARLES HARRISON, DAVID HARRISON and ROBERT HARRISON, CO-TRUSTEES OF THE MARY AND JAMES HARRISON FOUNDATION (All Grantors collectively referred to herein as "Grantor".)

Whose address is: The Mary and James Harrison Foundation
c/o BOKF, N.A. dba Bank of Oklahoma
9520 N. May Ave., Second Floor
Oklahoma City, OK 73120

GRANTEE: DCP MIDSTREAM, L.P., a Delaware Limited Liability Company

Whose address is: 3201 Quail Springs Parkway, Suite 100
Oklahoma City, OK 73134

EASEMENT TRACT:

A Thirty (30) foot wide strip of land being 94.18 rods in length in the W/2 E/2 SW/4 and E/2 SW/4 SW/4 of Section 23, Township 3 North, Range 4 West, Garvin County, OK, referred to as the Southern Oklahoma Pipeline, with the Pipeline Route being described on the attached Exhibit "A" made a part hereof; PROVIDED, HOWEVER, that the terms and provisions of this Pipeline Easement shall control over any discrepancies on Exhibit "A".

INSTALLATION PERIOD: Ninety (90) Days from execution of Pipeline Easement.

The undersigned Grantor, for good and valuable consideration and Grantee's promise to pay additional damages as set forth below, the receipt and sufficiency of which is hereby acknowledged, does hereby grant and convey unto Grantee, a **non-exclusive** easement to enter, construct, operate and maintain on the Easement Tract a single pipeline not to exceed Twelve (12) inches, to be installed at a minimum depth of Forty-eight (48) inches (the "Pipeline"), solely for the transportation of natural gas and oil, not to include salt water ("Sole Use"). Grantee has agreed and shall install the Pipeline in accordance with all state and federal laws and regulations. Grantee acknowledges its duty and responsibility for the continued maintenance of the surface area disturbed and any erosion which may occur as a result of the construction, operation or maintenance of the Pipeline; Grantee shall repair or be working diligently to repair any such damage or such erosion. Grantee shall maintain a minimum depth of forty-eight (48) inches for the Pipeline to insure safety and maintain drainage of the property. Grantee acknowledges its duty to maintain the Pipeline to protect the safety of Grantor's property, persons, livestock and the environment. In addition, Grantee shall compensate Grantor for any damages arising from the Pipeline construction, operation or maintenance or Grantee's use of the Easement Tract and Construction Area that occur to Grantor's property, whether within or outside of the Easement Tract, from and after the completion of construction, including but not limited to damages resulting from repairs, leaks or maintenance of the Pipeline. Grantor is only granting Grantee a non-exclusive easement, subject to termination as defined in Paragraph 8 herein. Grantor has also executed this instrument to evidence its agreement to all the terms and provisions hereof.

Page 1 of 9

I-2017-008315 Book 2194 Pg: 311
10/06/2017 8:00 am Pg 0311-0320
Fee: \$ 31.00 Doc: \$ 0.00
Lori Fulks - Garvin County Clerk
State of Oklahoma

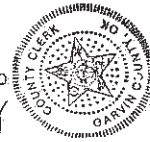

Page 1 of 10
BOKF

TITLE COMMITMENT

In connection with the foregoing grant, Grantor and Grantee further agree as follows:

1. Grantor may continue to use and enjoy the Easement Tract in any manner which does not unreasonably interfere with Grantee's Sole Use of the Easement Tract for the purposes described above. Grantor and Grantee agree that there is an existing creek on Grantor's property. With the exception of the existing creek, Grantor shall not intentionally (a) impound water upon the Easement Tract (b) change the ground elevation or grade of the Easement Tract, or (c) construct any building, structure, improvement or obstruction upon the Easement Tract which would interfere with Grantee's exercise of the rights set forth herein. Grantor reserves the right to construct fences across the Easement Tract. If any portion of the Easement Tract is used for ingress and/or egress whether now or in the future by Grantor, its lessees, or their respective successors or assigns, Grantee shall insure that its activities do not prevent or otherwise adversely affect such ingress and egress. Grantee's ingress and egress to the Easement Tract shall be limited to the existing county roads. This Easement does not constitute a conveyance of any of the oil, gas or other minerals on or underlying the Easement Tract.

2. No improvements located on the Easement Tract and Construction Area as defined in paragraph 4 below (including fences and future or present driveways) will be disturbed without prior written notice to Grantor (except in cases of emergency in which case notice will be given within twenty-four (24) hours of Grantee's notice of the emergency) and any damaged improvements shall be promptly repaired by Grantee in a good and workmanlike manner. Grantor and Grantee have agreed upon prior written notice to Grantor that during installation of the Pipeline that Grantee may cut any fence on the Easement Tract and Construction Area as defined in paragraph 4 below, provided Grantee at its sole cost installs proper H braces and gates. Grantee agrees and shall provide Grantor a key to all gates installed on the Easement Tract. Grantee agrees to maintain the security associated with the premises, within the Easement Tract and Construction Area at all times during the Installation Period and during all times when Grantee is conducting activities under this Easement. Further Grantee agrees to close any gate Grantee utilizes on Grantor's property, whether within the Easement Tract and Construction Area or outside of the same, to insure, without limitation, that all livestock are contained and protected, as well as protecting persons.

3. If necessary for the installation, operation, or maintenance of the Pipeline, Grantee may subject to Grantee's duties under Paragraph 5 herein below, after obtaining all necessary third party consents, remove any crops or grasses from the Easement Tract and Construction Area as defined in paragraph 4 below and in such event, Grantee shall pay to Grantor or other third parties, including Grantor's tenants, the reasonable value of any crops removed or damaged, loss of use, pay all costs to restore the Easement Tract and Construction Area as defined in paragraph 4 below to a suitable condition for planting of crops, shall re-seed any grasses in accordance with the provisions of this instrument promptly following said activities, and shall pay Grantor or Third-Parties for any actual damages to growing cash crops, loss of use, pasture, livestock, timber located outside the Easement Tract, drain tiles, existing fences, irrigation systems, including but not limited to water wells, pipes or casing, personal property, and/or other agricultural equipment caused by Grantee's exercise of rights granted herein. Grantee shall remove all effected trees within a reasonable time during the Installation Period. All rocks brought to the surface during construction will be removed or buried by Grantee to achieve the same density and size observed prior to the Pipeline construction or observed on and off the Easement Tract. After the installation of (or any repairs or maintenance to) the Pipeline, Grantee shall repair any damage to the Easement Tract and Construction Area as defined in paragraph 4 below caused by such activities promptly following the completion of such activities (including but not limited to the reasonable restoration of the surface of any affected land and the reseeded of any grassed areas in accordance with Natural Resource Conservation Service specifications and any cleanup required by any regulatory authority whether within or outside the limits of the Easement Tract and/or Construction Area), it being the parties' intent that Grantee will take any and all actions necessary, and pay any and all costs necessary, to cause the condition of the surface of the Easement Tract and Construction Area as defined in paragraph 4 below to be substantially the same as the condition that existed on the date hereof. If after the restoration of the soil to substantially the same condition as existed prior to such installation, repair or maintenance there is excess soil, rock or other materials (collectively "Excess Materials"), Grantee shall

Page 2 of 9

I-2017-008315 Book 2194 Pg: 312
10/06/2017 8:00 am Pg 0311-0320
Fee: \$ 31.00 Doc: \$ 0.00
Lori Fuiks - Garvin County Clerk
State of Oklahoma

page 2 of 10
Book

TITLE COMMITMENT

own and shall remove any Excess Materials from the Easement Tract and Construction Area as defined in paragraph 4 below without any further compensation to Grantor, unless the Excess Materials have a readily ascertainable market value of \$100.00 or greater, in which event Grantee shall have the right to either (a) leave the Excess Materials on site and disclaim any rights thereto, or (b) pay Grantor the fair market value thereof, less the Grantee's removal costs.

4. During the Installation Period, Grantee may enter upon and use an additional Twenty (20) feet adjoining the Easement tract ("Construction Area") to the extent reasonably necessary in connection with the installation of the Pipeline. Grantee shall repair any damage caused by the activities of Grantee on any part of any Construction Area promptly following the completion of those activities (including but not limited to the reasonable restoration of the surface of any affected land and the reseeding of any grassed areas in accordance with Natural Resource Conservation Service specifications), it being the parties' intent that Grantee will take any and all actions necessary, and pay any and all costs necessary, to cause the condition of the Construction Area is substantially the same as the condition that existed on the date hereof. Grantee shall have no surface rights after the initial installation of the Pipeline is completed, except for (i) periodic maintenance and repair work and related activities, which may include vent pipes and cathodic protection equipment installed on the Pipeline within the Easement Tract. PROVIDED, HOWEVER, Grantee agrees that any vent pipes or boxes above the surface shall be painted and installed within the Easement Tract and any wires to be installed for the cathodic protection system laid horizontally shall be installed at a minimum depth of 48 inches, except when the cathodic protection system requires the wires to come to the surface box to remove the charge or return from the box to the Pipeline, and all pipes associated with the cathodic protection system shall be installed in the Easement Tract with painted pipe barriers around any concrete pad or boxes erected above the surface of the ground on the Easement Tract, and (ii) signage which identifies the location of the Pipeline, including but not limited to at each fence line crossed.

5. Grantor shall not be required to provide any title materials and Grantee shall complete its own title inspections. Grantee's rights hereunder are expressly made subject to any and all third-party rights, including both surface and subsurface rights. Likewise, Grantee shall be responsible for obtaining any and all third-party consents necessary in connection with this instrument (including consents by Tenants, if any), and Grantee shall pay any and all costs, expenses or damages incurred by any Tenant or other third party as the result of Grantee's activities or violation of the terms of this instrument ("Third Party Claims"). Grantee has knowledge that Grantor in the past has granted other easements on Grantor's Property. Grantee agrees it is Grantee's duty to insure the non-exclusive easement granted herein shall not affect or interfere with those previously granted easements, wind leases, leases, agreements or options.

6. Grantee shall be responsible and liable for any pollutants resulting from its operations on Grantor's property, whether within or outside the Easement Tract and Construction Area, including but not limited to any pond, stream, creek, pasture, cropland, and underground fresh water zones.

7. Grantee and its successors and assigns shall indemnify Grantor, their heirs, successors, and assigns from and against all claims, injuries, suits, damages, costs, losses, and reasonable expenses for all claims, including but not limited to Third-Party Claims, arising out of any of the actions of Grantee and/or its employees, agents, and/or other representatives, including, without limitation, claims regarding the construction, maintenance, repair, use or existence of the Pipeline, whether incurred within or outside of the Easement Tract. This indemnification shall survive the termination of this Easement and shall be unlimited in time and amount unless contrary to law.

8. The terms, conditions, and provisions of this Agreement shall extend to and be binding upon the heirs, devisees, executors, administrators, successors and permitted assigns of Grantor and Grantee; PROVIDED, HOWEVER, that if Grantee fails to install the Pipeline before the end of the installation Period, or fails to utilize or maintain the Pipeline as a usable pipeline for any full twelve (12) month consecutive period after installation is completed this shall be considered abandonment by Grantee of the Easement herein granted and this Pipeline Easement shall terminate and the Easement

Page 3 of 9

I-2017-008315 Book 2194 Pg. 313
10/06/2017 8:00 am Pg 0311-0320
Fee: \$ 31.00 Doc: \$ 0.00
Lori Fulks - Garvin County Clerk
State of Oklahoma

page 3 of 9
B.C.D.

TITLE COMMITMENT

Tract shall automatically revert to Grantor without Court intervention and Grantee, its successors and assigns, shall have no further rights hereunder and shall execute a Release of this Easement at the request of Grantor. In such event, Grantee may either elect to, (a) remove the Pipeline and repair and restore the Easement Tract to conditions existing prior to Grantee's installation of the Pipeline; or (b) purge the Pipeline of product, fill the line with a non-hazardous inert substance standard to the industry, cap the Pipeline and abandon the Pipeline in place.

9. It is understood and agreed that Grantee shall have no right to dispose of deleterious substances on Grantor's property, or let the same run onto Grantor's property, stock tanks, ponds or any natural creek, stream, river, or other body of water. Grantee agrees at its sole expense to remove all deleterious substances from Grantor's property caused by Grantee's activities. Should deleterious substances spill or discharge from Grantee's actions under this Easement, whether accidentally or intentionally, Grantee shall immediately remediate the spill/discharge in accordance with local, state and federal guidelines and pay damages to Grantor and Grantor's tenants for all damage to crops, pasture, soil and loss of use of the property, which compensation shall continue until such time as the property is restored to its condition prior to the spill or discharge unless Grantor and Grantee shall enter into a settlement agreement, which settlement shall be governed by a separate written agreement between Grantor and Grantee.

10. Grantee will take no action nor permit any action which could permanently alter the natural water drainage of the Easement Tract and/or any of Grantor's adjacent property.

11. Grantee warrants and represents to Grantor that all operations conducted by Grantee shall be performed in a prudent and workmanlike manner and shall be in compliance with the rules and regulations of the Oklahoma Corporation Commission and any other applicable Federal and State regulation(s).

12. This Pipeline Easement may be assigned by Grantee in whole or in part to any subsidiary or affiliate of Grantee upon prior written notice to Grantor without Grantor's consent. For any other assignments, Grantee shall only assign its interest in this Easement in compliance with this paragraph. In order to assign this Easement, Grantee must obtain the proposed assignee's signed agreement acknowledging it shall be bound by the terms of this Easement, then present the assignee's acknowledgement to Grantor to obtain Grantor's written consent to said assignment, which consent shall not be unreasonably withheld, if the proposed Assignee has assets equal to or greater than the original Grantee at the time of the execution of this Pipeline Easement.

13. Grantee is required to obtain liability insurance, with a reputable carrier, for no less than \$1,000,000.00 of coverage, and Grantee shall provide Grantor with a copy of the certificate of liability insurance prior to execution of this Easement. Grantee shall carry this insurance for as long as this Easement is in effect. Upon Grantor's written request from time to time, but no more than once annually, Grantee shall provide Grantor with a copy of the certificate of liability insurance. Grantee shall insure that all of its subcontractors and agents performing work on behalf of Grantee relating to this Pipeline Easement shall have insurance coverage comparable to Grantee or be covered by Grantee's policy. Maintenance by Grantee of said insurance shall not be considered a limitation on damages to be paid by Grantee or the indemnity provisions imposed on Grantee herein.

14. Grantor is acting as a fiduciary and is executing this instrument solely in its fiduciary capacity. Grantor shall have no liability whatsoever in its separate corporate and/or individual capacity on any agreement, covenant or representation contained in this instrument. Notwithstanding anything contained herein, Grantor makes no warranties, either express or implied, regarding the Easement Tract. All consideration received by Grantor shall be fully earned upon receipt and shall not be refundable under any circumstance.

Page 4 of 9

I-2017-008315 Book 2194 Pg: 314
10/06/2017 8:00 am Pg 0311-0320
Fee: \$ 31.00 Doc: \$ 0.00
Lori Fulks - Garvin County Clerk
State of Oklahoma

page #810
Book

TITLE COMMITMENT

15. This instrument may be executed in counterparts, any one of which need not contain the signatures of more than one party, but all such counterparts taken together shall constitute one and the same instrument.

Executed this 20 day of Sept, 2017.

GRANTOR:

John Harrison
JOHN HARRISON, CO-TRUSTEE OF THE MARY AND
JAMES HARRISON FOUNDATION

ACKNOWLEDGMENT

State of OK)
County of OK) ss

Before me, the undersigned, a Notary Public in and for said County and State, on this 20 day of Sept, 2017, personally appeared, JOHN HARRISON, CO-TRUSTEE OF THE MARY AND JAMES HARRISON FOUNDATION to me known to be the identical person who subscribed his name to the foregoing, and acknowledged to me that he executed the same as his free and voluntary act and deed, for the uses and purposes therein set forth.

My Commission Expires:

Kathy Crane
Notary Public

Commission No. _____



Page 5 of 9

I-2017-008315 Book 2194 Pg: 315
10/06/2017 8:00 am Pg 0311-0320
Fee: \$ 31.00 Doc: \$ 0.00
Lori Fulks - Garvin County Clerk
State of Oklahoma

page 5 of 10
Book

TITLE COMMITMENT

GRANTOR:

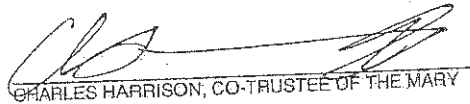
CHARLES HARRISON, CO-TRUSTEE OF THE MARY
AND JAMES HARRISON FOUNDATION

ACKNOWLEDGMENT

State of Oklahoma)
County of Oklahoma) ss

Before me, the undersigned, a Notary Public in and for said County and State, on this 7th day of August, 2017, personally appeared, CHARLES HARRISON, CO-TRUSTEE OF THE MARY AND JAMES HARRISON FOUNDATION to me known to be the identical person who subscribed his name to the foregoing, and acknowledged to me that he executed the same as his free and voluntary act and deed, for the uses and purposes therein set forth.

My Commission Expires:

8-12-21

Commission No. 13607346

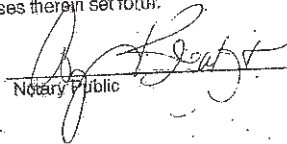
Notary Public

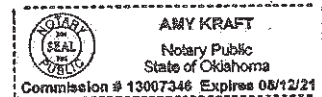

Page 6 of 9

page 6 of 10
BOKF

1-2017-008315 Book 2194 Pg. 316
10/06/2017 8:00 am Pg 0311-0320
Fee: \$ 31.00 Doc: \$ 0.00
Lori Fuiks - Garvin County Clerk
State of Oklahoma

TITLE COMMITMENT

GRANTOR:

David Harrison
DAVID HARRISON, CO-TRUSTEE OF THE MARY AND
JAMES HARRISON FOUNDATION

ACKNOWLEDGMENT

State of Oklahoma)
County of Garvin) ss

Before me, the undersigned, a Notary Public in and for said County and State, on this 8th day of September, 2017, personally appeared, DAVID HARRISON, CO-TRUSTEE OF THE MARY AND JAMES HARRISON FOUNDATION to me known to be the identical person who subscribed his name to the foregoing, and acknowledged to me that he executed the same as his free and voluntary act and deed, for the uses and purposes therein set forth.

My Commission Expires:

10-12-19

Commission No. 99016016

Loretta Elmoro
Notary Public

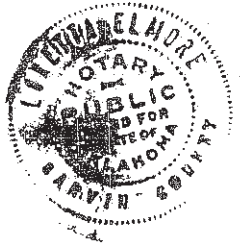

Page 7 of 9

1-2017-008315 Book 2194 Pg: 317
10/06/2017 8:00 am Pg. 0311-0320
Fee: \$ 31.00 Doc: \$ 0.00
Lori Fulks - Garvin County Clerk
State of Oklahoma

page 7 of 9
Book

TITLE COMMITMENT

GRANTOR:

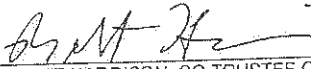
ROBERT HARRISON, CO-TRUSTEE OF THE MARY
AND JAMES HARRISON FOUNDATION

ACKNOWLEDGMENT

State of Oklahoma }
County of Beaver } ss

Before me, the undersigned, a Notary Public in and for said County and State; on this 18th day of September, 2017, personally appeared, ROBERT HARRISON, CO-TRUSTEE OF THE MARY AND JAMES HARRISON FOUNDATION to me known to be the identical person who subscribed his name to the foregoing, and acknowledged to me that he executed the same as his free and voluntary act and deed, for the uses and purposes therein set forth.

My Commission Expires:

2-3-20
Commission No. 16001115

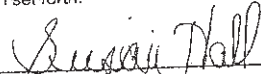
Notary Public



Page 8 of 9

1:2017-008315 Book 2194 Pg: 318
10/06/2017 8:00 am Pg 0311-0320
Fee: \$ 31.00 Doc: \$ 0.00
Lori Fulks - Garvin County Clerk
State of Oklahoma

page 8 of 10
Book F
m.

TITLE COMMITMENT

GRANTEE:

DCP MIDSTREAM, L.P., a Delaware Limited Liability Company

BY: [Signature]
Name: John W. Sullivan
Title: Attorney in Fact

ACKNOWLEDGMENT

State of OKLAHOMA)
County of OKLAHOMA) ss

This instrument was acknowledged before me, the undersigned authority, a Notary Public in and for the State of Oklahoma, on the 22nd day of SEPT, 2017, by John W. Sullivan as ~~Attorney in Fact~~ of DCP MIDSTREAM, L.P., a Delaware Limited Liability Company for and on behalf of DCP MIDSTREAM, L.P., a Delaware Limited Liability Company, known to me to be the person whose name is subscribed to the foregoing instrument, and she acknowledged to me that he/she executed the same for the purposes and consideration herein expressed.

My Commission Expires:

[Signature]
Notary Public



Commission No. _____

pg 9 of 10
BUE

TITLE COMMITMENT



Nature of Work PRELIMINARY SURVEY Date 08/23/17 Line No. _____
 Asset SOUTHERN OKLAHOMA System _____ Subsystem _____ A/E No. 500216323
 SW/4 Sec. 23 Twp. JN Range 4W Co. GARYN State OK RC No. L282 Sheet No. 3 OF 5

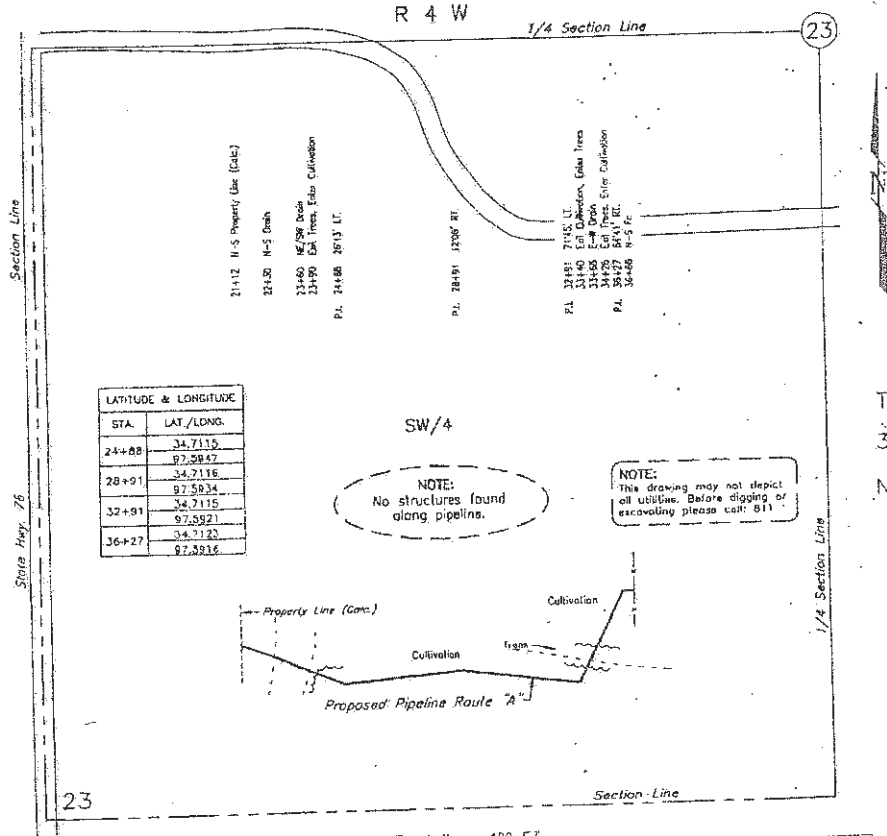

LATITUDE & LONGITUDE	
STA.	LAT./LONG.
24+88	34.7115
	97.5847
28+91	34.7116
	97.5834
32+91	34.7115
	97.5821
36+27	34.7123
	97.5816

Remarks _____
TRACT #4 - W/2 E/2 SW/4 & E/2 SW/4 SW/4 SECTION 23 - MARY AND JAMES HARRISON
FOUNDATION - 1.554 FEET OR 94.18 RODS

6	7	8	9	10	11	12
13	14	15	16	17	18	19
20	21	22	23	24	25	26
27	28	29	30	31	32	33
34	35	36	37	38	39	40

DWG. NO. CIM170433C Group or Corporate Staff DGP Midstream
 Signed _____



1:2017-008315 Book 2194 Pg: 320
 10/06/2017 8:00 am Pg 0311-0320
 Fee: \$ 31.00 Doc: \$ 0.00
 Lori Fulks - Garvin County Clerk
 State of Oklahoma

Done 10/10/17
 Bora

THURSDAY, JANUARY 31 • 1:00 PM

TAX CARDS

800.451.2709
SchraderAuction.com

 **SCHRADER**
Real Estate and Auction Company, Inc.

TAX CARDS

Tammy Murrah, Garvin County Assessor
Pauls Valley, OK. 73075

Parcel Number 0000-23-03N-04W-0-005-00
Name HARRISON, MARY & JAMES
Owner Number 40,745.00 DBA

School District I9 Lindsay
Deed Book/Page 1942 / 597
Tax ID: 8,305

Legal Description

W7.50A SW SE NW
QCD 1942-597

77.50A X W/2 E/2 SW X E/2 SW SW

X SE NE SW
QCD/1519-630



0000-23-03N-04W-0-005-00-000.jpg

Acres 77.500

Lots

Land Use RuralAg

	Market	Assessed
Land	17,351	1,909
Improvements	37,734	4,151
Misc	7,095	780
Mfg Home	0	0
Total	62,180	6,840
Base Homestead		0
Additional Homestead		0
Disabled Veteran		0
Net Assessed		6,840

Mail Address

HARRISON, MARY & JAMES
FOUNDATION
9520 N MAY SUITE 200

OKLAHOMA CITY, OK. 73120

Property Location

0 07539
LINDSAY

Coordinate Information

Description Latitude Longitude

TAX CARDS

Tammy Murrah, Garvin County Assessor
Pauls Valley, OK. 73075

Parcel Number 0000-23-03N-04W-0-005-00
Name HARRISON, MARY & JAMES
Owner Number 40,745.00 DBA

School District I9 Lindsay
Deed Book/Page 1942 / 597
Tax ID: 8,305



0000-23-03N-04W-0-005-00-001.jpg



0000-23-03N-04W-0-005-00-002.JPG



0000-23-03N-04W-0-005-00-003.JPG



0000-23-03N-04W-0-005-00-004.JPG



0000-23-03N-04W-0-005-00-005.jpg



0000-23-03N-04W-0-005-00-006.jpg

TAX CARDS

Tammy Murrah, Garvin County Assessor
Pauls Valley, OK. 73075

Parcel Number 0000-23-03N-04W-0-005-00
Name HARRISON, MARY & JAMES
Owner Number 40,745.00 DBA

School District I9 Lindsay
Deed Book/Page 1942 / 597
Tax ID: 8,305



0000-23-03N-04W-0-005-00-001.jpg



0000-23-03N-04W-0-005-00-002.JPG



0000-23-03N-04W-0-005-00-003.JPG



0000-23-03N-04W-0-005-00-004.JPG



0000-23-03N-04W-0-005-00-005.jpg



0000-23-03N-04W-0-005-00-006.jpg

TAX CARDS

Tammy Murrah, Garvin County Assessor
Pauls Valley, OK. 73075

Parcel Number 0000-23-03N-04W-0-005-00
Name HARRISON, MARY & JAMES
Owner Number 40,745.00 **DBA**

School District 19 Lindsay
Deed Book/Page 1942 / 597
Tax ID: 8,305

Legal Description

W7.50A SW SE NW
QCD 1942-597

77.50A X W/2 E/2 SW X E/2 SW SW

X SE NE SW
QCD/1519-630



0000-23-03N-04W-0-005-00-000.jpg

Acres 77.500

Lots

Land Use RuralAg

	Market	Assessed
Land	17,351	1,909
Improvements	37,734	4,151
Misc	7,095	780
Mfg Home	0	0
Total	62,180	6,840
Base Homestead		0
Additional Homestead		0
Disabled Veteran		0
Net Assessed		6,840

Mail Address

HARRISON, MARY & JAMES
FOUNDATION
9520 N MAY SUITE 200

OKLAHOMA CITY, OK. 73120

Property Location

0 07539
LINDSAY

Coordinate Information

Description Latitude Longitude

TAX CARDS

0000-23-03N-04W-0-005-00 Page 1 of 2
 W7.50A SW SE NW 77.50A X W/
 2 E/2 SW X E/2 SW SW X SE NE
 SW QCD 1942-597

Req By: LDLEWIS 10/26/18 11:29:10 OKLA. CO. #25 WORKING FI
 HARRISON, MARY & JAMES
 FOUNDATION
 9520 N MAY SUITE 200

OKLAHOMA CITY OK 731200000
 Site Address: 000000 07539

BLDG # 1
 Stories/Style 1 One Story
 Occupancy 1 Single Fami
 Design 0001 TRADITIONAL
 Quality 05 Class C FA
 Roof Type 01 GABLE
 Roof Material 1 COMP SHG CL
 Exterior Wall-1 2 WOOD CLASS
 Exterior Wall-2 "C" CONVNTN
 Foundation 2 C AVERAGE
 Interior Fin 3 "C" AVERAGE
 Floor Cover 3
 No. Bedrooms 003
 No. Baths 2
 Total Rooms 005
 Heating 1 FORCED AIR
 Air Condition 1 FORCED AIR
 Fireplace #1
 Fireplace #2
 Primary Garage
 Primary Porch 3 OpnPorch Cl
 Basement
 Actual Year Blt 1959
 Year Remodeled 2010
 Eff. Year Built 1992
 Condition 3
 Normal Depr Tbl CA
 Functional Obs. 000000
 Economic Obs. 000000
 Observed Depr. 000000
 Obsvd Depr Code
 RENT
 Cnty Adj. Fact. 000
 Cnty Adj. Fact. 000

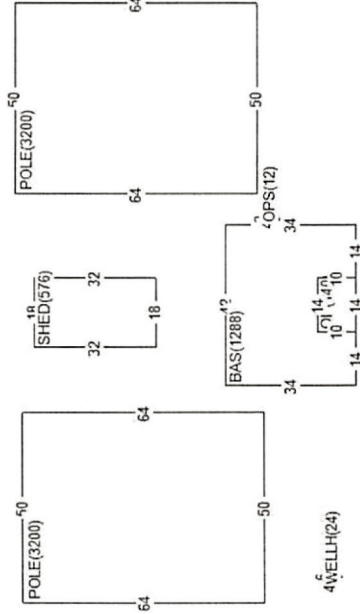

Land Value 24,193
 Misc Value 9,701
 Bldg Value 51,841
 Total Value 85,735
 Value By CAMA

Effective Area 1,288
 Points 0.0000
 RCN 77,374
 Pct Good 0.6700
 Obsol/Observed 0.0000
 Building Value 51,841
 Bldg RNCLD/SF 40.25

BOOK PAGE DATE QS SALE PRICE
 1942 597 1210 MU

PERMIT NO TYPE DATE AMOUNT

Appraiser TAS4 TASC-NONE
 Appr Date 05/12/16
 Use Code 0001 RURAL AG
 NBHD 9000.04 RURAL NBHD FIVE
 L100 M100 B100



MISC BLDG CODE	DESC	WIDTH	LENGTH	AREA	FLAT	HEATED	UNITS	ADJ PRICE	EVB DT PCT	ADJUSTMENT	VALUE																																									
1	1 POLE	50.00	64.00	3200.00	140	1288	3200.00	3.00	1980 CA	48.00	4,608																																									
2	1 HAY	18.00	32.00	576.00	24	6400	576.00	1.80	1970 CA	39.00	404																																									
3	1 POLE	50.00	64.00	3200.00	576	12	3200.00	3.00	1980 CA	48.00	4,608																																									
4	1 OPSC	3.00	4.00	12.00	12		12.00	18.65	1959 CA	36.00	81																																									
<table border="1"> <thead> <tr> <th>LAND LUSE DESC</th> <th>ZONING</th> <th>UNITS TP</th> <th>PRICE</th> <th>ADJUSTMENT CODE/FACTOR</th> <th>VALUE</th> </tr> </thead> <tbody> <tr> <td>1 56 Port FSL overwas</td> <td>TM</td> <td>7.00 AC</td> <td>87.00</td> <td>AG .00</td> <td>968</td> </tr> <tr> <td>2 84 Yahola FSL</td> <td>TM</td> <td>3.00 AC</td> <td>68.00</td> <td>AG 1.59</td> <td>324</td> </tr> <tr> <td>3 26 Grainola CL 2-5%</td> <td>TM</td> <td>3.00 AC</td> <td>33.00</td> <td>AG 1.59</td> <td>157</td> </tr> <tr> <td>4 26 Grainola CL 2-5%</td> <td>IP</td> <td>27.50 AC</td> <td>33.00</td> <td>AG 4.45</td> <td>4,038</td> </tr> <tr> <td>5 39 Konawa FSL 2-5%</td> <td>IP</td> <td>4.00 AC</td> <td>44.00</td> <td>AG 4.45</td> <td>783</td> </tr> <tr> <td>6 10 Chigley Grav SL</td> <td>IP</td> <td>3.00 AC</td> <td>26.00</td> <td>AG 4.45</td> <td>347</td> </tr> </tbody> </table>											LAND LUSE DESC	ZONING	UNITS TP	PRICE	ADJUSTMENT CODE/FACTOR	VALUE	1 56 Port FSL overwas	TM	7.00 AC	87.00	AG .00	968	2 84 Yahola FSL	TM	3.00 AC	68.00	AG 1.59	324	3 26 Grainola CL 2-5%	TM	3.00 AC	33.00	AG 1.59	157	4 26 Grainola CL 2-5%	IP	27.50 AC	33.00	AG 4.45	4,038	5 39 Konawa FSL 2-5%	IP	4.00 AC	44.00	AG 4.45	783	6 10 Chigley Grav SL	IP	3.00 AC	26.00	AG 4.45	347
LAND LUSE DESC	ZONING	UNITS TP	PRICE	ADJUSTMENT CODE/FACTOR	VALUE																																															
1 56 Port FSL overwas	TM	7.00 AC	87.00	AG .00	968																																															
2 84 Yahola FSL	TM	3.00 AC	68.00	AG 1.59	324																																															
3 26 Grainola CL 2-5%	TM	3.00 AC	33.00	AG 1.59	157																																															
4 26 Grainola CL 2-5%	IP	27.50 AC	33.00	AG 4.45	4,038																																															
5 39 Konawa FSL 2-5%	IP	4.00 AC	44.00	AG 4.45	783																																															
6 10 Chigley Grav SL	IP	3.00 AC	26.00	AG 4.45	347																																															

AC 77.50

TAX CARDS

0000-23-03N-04W-0-005-00 Page 2 of 2 Req By: LDLEWIS 10/26/18 11:29:10 OKLA. CO. #25 WORKING FI
 HARRISON, MARY & JAMES
 FOUNDATION
 9520 N MAY SUITE 200
 OKLAHOMA CITY OK 731200000
 Site Address: 000000 07539
 Land Value 0
 Misc Value 0
 Bldg Value 0
 Total Value 0
 Value By CAMA

BOOK PAGE DATE QS SALE PRICE
 PERMIT NO TYPE DATE AMOUNT
 Appraiser TAS4 TASC-NONE
 Appr Date 05/12/16
 Use Code 0001 RURAL AG
 NBHD 9000.04 L100 M100 B100

History Values
 Tax Year Total Appraised Value
 15 81,756
 13 83,979
 05 55,516

LAND LUSE DESC	ZONING	UNITS TP	PRICE	ADJUSTMENT CODE/FACTOR	VALUE
7 84 Yahola FSL	IP	3.00 AC	68.00	AG 4.45	.00
8 56 Port FSL overwas	CR	22.00 AC	87.00	AG 6.68	.00
9 26 Grainola CL 2-5†	CR	4.00 AC	33.00	AG 6.68	.00
10 AIHM Area 1 Homesite		1.00 AC	3000.00	.00	.00
					908
					12,786
					882
					3,000

TAX CARDS

0000-26-03N-04W-0-002-00

Page 2 of 2

Req By: IDLEWIS
HARRISON, MARY & JAMES
FOUNDATION
9520 N MAY SUITE 200

10/26/18 11:29:37 OKLA. CO. #25

WORKING FI

Site Address: 000000 OKLAHOMA CITY OK 731200000
07569

Land Value 0
Misc Value 0
Bldg Value 0
Total Value 0
Value By CAMA

BOOK PAGE DATE QS SALE PRICE

PERMIT NO TYPE DATE AMOUNT

Appraiser TAS4 TASC-NONE
Appr Date 05/13/16
Use Code 0001 RURAL AG
NBHD 9000.04 L100 M100 B100

History Values
Tax Year Total Appraised Value
15 60,077
13 60,077
05 60,077

LAND USE	DESC	ZONING	UNITS	TP	PRICE	ADJUSTMENT CODE/FACTOR	VALUE
7 56	Port FSL overwas	CR	46.00	AC	87.00	.00	26,733
8 26	Grainola CL 2-5%	CR	6.00	AC	33.00	.00	1,323

THURSDAY, JANUARY 31 • 1:00 PM

PROPERTY PHOTOS

800.451.2709
SchraderAuction.com

 **SCHRADER**
Real Estate and Auction Company, Inc.



Property from the North



Tract #1



Tract #1



Tract #1



Tract #1



Tract #1



Tract #1



Tract #2



Tract #2



Tract #2



Tract #3



Tract #3



Tract #3



Tract #3





Tract #3



Tract #3



Tract #3



Tract #3



Tract #3



Tract #3



Tract #1



Tract #4



Tract #4



Tract #4

THURSDAY, JANUARY 31 • 1:00 PM



 **SCHRADER**
Real Estate and Auction Company, Inc.

PO Box 508

950 North Liberty Drive

Columbia City, IN 46725

800.451.2709

260.244.7606

www.schraderauction.com

NAA
Auctioneer
RC19-731

Follow Us and Get Our New Schrader iOS App:



YouTube



Download on the
App Store

