

Real Estate AUCTION

- Next to Lancaster Park
- Across from Lancaster Elementary School
- Water & Sewer in the Area
(call for additional information)
- Zoned R1

Wells County, IN

79[±] acres

OFFERED IN 6 TRACTS



800.451.2709
SchraderAuction.com

Thursday, May 21 • 6pm

at Wells County 4-H Park, Bluffton, IN • Online Bidding Available

INFORMATION Booklet



TRACT 3



TRACT 6

Disclaimer

This information booklet includes information obtained or derived from third-party sources. Although believed to be accurate and from reliable sources, such information is subject to verification and is not intended as a substitute for a prospective buyer's independent review and investigation of the property. Prospective buyers are responsible for completing their own due diligence.

THIS PROPERTY IS OFFERED "AS IS, WHERE IS". NO WARRANTY OR REPRESENTATION, STATED OR IMPLIED, IS MADE CONCERNING THE PROPERTY. Without limiting the foregoing, Owner and Auction Company and their respective agents and representatives, assume no liability for (and disclaim any and all promises, representations and warranties with respect to) the information and reports contained herein.

Auction Managers

Al Pfister • 260.760.8922 & Mike Roy • 260.437.5428



950 N. Liberty Dr., Columbia City, IN 46725
800.451.2709 | 260.244.7606
www.schraderauction.com

Follow us and download our Schrader iOS app



BOOKLET INDEX



Real Estate Auction Registration Forms

Location Map

Tract Map

Tract Descriptions & Auction Terms

Soils Map & Productivity Information

Topography Map

Zoning Map

County Property Reports

Tax Statements

Preliminary Title

Property Photos

BIDDER PRE-REGISTRATION FORM

THURSDAY, MAY 21, 2026

79± ACRES – WELLS COUNTY, INDIANA

For pre-registration, this form must be received at Schrader Real Estate and Auction Company, Inc.,
P.O. Box 508, Columbia City, IN, 46725,

Email to auctions@schraderauction.com or fax to 260-244-4431, no later than Thursday, May 14, 2026.
Otherwise, registration available onsite prior to the auction.

BIDDER INFORMATION

(FOR OFFICE USE ONLY)

Name _____

Bidder # _____

Address _____

City/State/Zip _____

Telephone: (Res) _____ (Office) _____

My Interest is in Tract or Tracts # _____

BANKING INFORMATION

Check to be drawn on: (Bank Name) _____

City, State, Zip: _____

Contact: _____ Phone No: _____

HOW DID YOU HEAR ABOUT THIS AUCTION?

Brochure Newspaper Signs Internet Radio TV Friend

Other _____

WOULD YOU LIKE TO BE NOTIFIED OF FUTURE AUCTIONS?

Regular Mail E-Mail E-Mail address: _____

Tillable Pasture Ranch Timber Recreational Building Sites

What states are you interested in? _____

Note: If you will be bidding for a partnership, corporation or other entity, you must bring documentation with you to the auction which authorizes you to bid and sign a Purchase Agreement on behalf of that entity.

I hereby agree to comply with terms of this sale including, but not limited to, paying all applicable buyer's premiums, and signing and performing in accordance with the contract if I am the successful bidder. Schrader Real Estate and Auction Company, Inc. represents the Seller in this transaction.

Signature: _____ Date: _____

**Online Auction Bidder Registration
79± Acres • Wells County, Indiana
Thursday, May 21, 2026**

This form and deposit are only required if you cannot attend the auction and wish to bid remotely through our online bidding system.

This registration form is for the auction listed above only. The person signing this form is personally responsible for any bids placed on the auction site, whether bidding on behalf of their personal account or on behalf of a corporation or other third party. If you are bidding on behalf of a third party, you are responsible for obtaining the necessary documentation authorizing you to bid on behalf of the third party. Schrader Real Estate and Auction Co., Inc. will look to the herein registered bidder for performance on any bid placed on this auction if you are the successful high bidder.

As the registered bidder, I hereby agree to the following statements:

1. My name and physical address is as follows:

My phone number is: _____

2. I have received the Real Estate Bidder's Package for the auction being held on Thursday, May 21, 2026 at 6:00 PM (EST).
3. I have read the information contained in the Real Estate Bidder's Package as mailed to me or by reading the documents on the website (www.schraderauction.com) and understand what I have read.
4. I hereby agree to comply with all terms of this sale, including paying all applicable buyer's premiums, and signing and performing in accordance with the Real Estate Purchase Agreement if I am the successful bidder.
5. I understand that Schrader Real Estate and Auction Co., Inc. represent the Seller in this transaction.
6. I am placing a deposit with Schrader Real Estate and Auction Co., Inc. Escrow in the amount of \$_____. I understand that the maximum bid or combination of bids I place may not exceed an amount equal to ten times the amount of my deposit. My deposit is being conveyed herewith in the form of a cashier's check payable to Schrader Real Estate and Auction, Co., Inc. Escrow or via wire transfer to the escrow account of Schrader Real Estate and Auction, Co., Inc. per the instructions below. I understand that my deposit money will be returned in full via wire transfer on the next business day if I am not the successful high bidder on any tract or combination of tracts.

Schrader Real Estate & Auction Company, Inc.
950 North Liberty Drive / P.O. Box 508, Columbia City, IN 46725
Phone 260-244-7606; Fax 260-244-4431; email: auctions@schraderauction.com

For wire instructions please call 1-800-451-2709.

7. My bank routing number is _____ and bank account number is _____.
(This for return of your deposit money). My bank name, address and phone number is:

8. **TECHNOLOGY DISCLAIMER:** Schrader Real Estate and Auction Co., Inc., its affiliates, partners and vendors, make no warranty or guarantee that the online bidding system will function as designed on the day of sale. Technical problems can and sometimes do occur. If a technical problem occurs and you are not able to place your bid during the live auction, Schrader Real Estate and Auction Co., Inc., its affiliates, partners and vendors will not be held liable or responsible for any claim of loss, whether actual or potential, as a result of the technical failure. I acknowledge that I am accepting this offer to place bids during a live outcry auction over the Internet *in lieu of actually attending the auction* as a personal convenience to me.

9. This document and your deposit money must be received in the office of Schrader Real Estate & Auction Co., Inc. by **4:00 PM, Thursday, May 14, 2026**. Send your deposit and return this form via fax or email to: **260-244-4431 or auctions@schraderauction.com**.

I understand and agree to the above statements.

Registered Bidder's signature

Date

Printed Name

This document must be completed in full.

Upon receipt of this completed form and your deposit money, you will be sent a bidder number and password via e-mail. Please confirm your e-mail address below:

E-mail address of registered bidder: _____

Thank you for your cooperation. We hope your online bidding experience is satisfying and convenient. If you have any comments or suggestions, please send them to:
kevin@schraderauction.com or call Kevin Jordan at 260-244-7606.

LOCATION MAP

LOCATION MAP

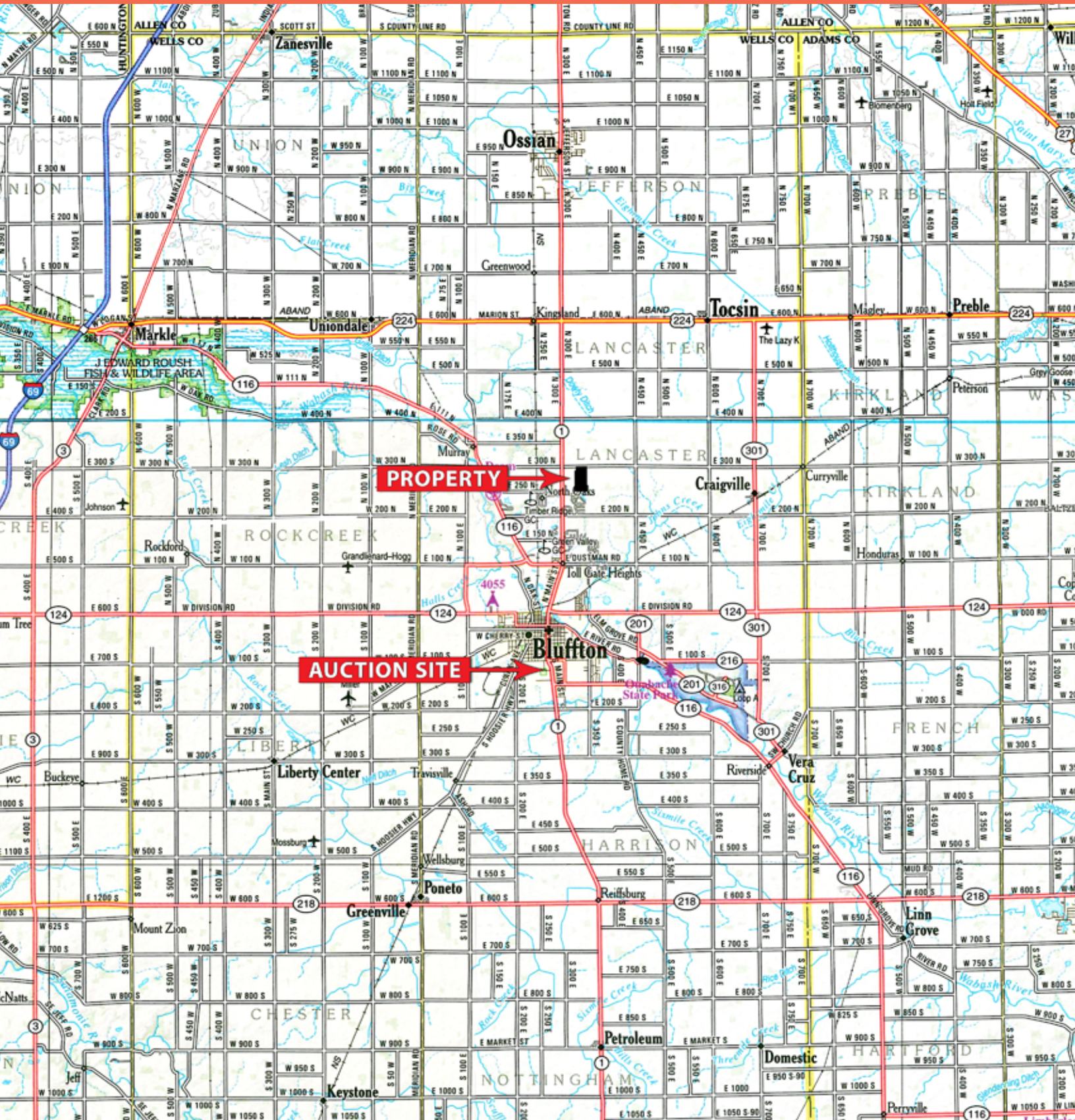

Auction Location: Wells County 4-H Park,
1240 4-H Park Rd, Bluffton, IN 46714

Property Location: **From Bluffton** – travel north
on St Rd 1 for 3 miles to CR 300 N (*Jackson St*),
turn east 0.3 miles to the property.



Online Bidding Available: You may bid online
during the auction at www.schraderauction.com.

You must be registered One Week in Advance
of the Auction to bid online. For online bidding
information, call Schrader Auction Company.

LOCATION MAP



Railroad

E 300 N

Jackson St

E 300 N

Lancaster Elementary School

Lancaster Park

Kingdom Hall of Jehovah's Witnesses

ITown Ministries

Auction Property

Main St

E 200 N

Monroe St

E 200 N

TRACT MAP

TRACT MAP



Jackson St

3 2± acres

1 9± acres

4 22± acres

2 9± acres

5 21± acres

6 16± acres

Open House: Thursday, April 16 • 4-6pm
Saturday, April 25 • 10am - Noon

TRACT DESCRIPTIONS

Real Estate AUCTION

Wells County, IN

Thursday, May 21 • 6pm

at Wells County 4-H Park, Bluffton, IN • Online Bidding Available

79[±] acres

OFFERED IN 6 TRACTS

TRACT 1: 9[±] acres, mostly tillable with frontage on Jackson St. Soils are primarily Glynwood Silt Loam.

TRACT 2: 9[±] acres, access is 25' of deeded from Jackson St. Soils are primarily Pewamo and Glynwood.

TRACT 3: 2[±] acres along Jackson St. Single-family home, 1416 sq. ft., 2-story home, two bedrooms, one bath. Other improvements are a detached garage, pole barn and 2 storage buildings.

TRACT 4: 22[±] acres, mostly tillable with frontage along Jackson St. Soils are mostly Pewamo and Blount-Del Ray.

TRACT 5: 21[±] acres, mostly tillable with 25' of deeded access from Jackson St. Soils are mostly Glynwood & Blount-Del Ray.

TRACT 6: 16[±] acres, with deeded access from Jackson St. Beautiful secluded country home. Built in 2000, 3,697 sq. ft. above grade, with two bedrooms, 3 full baths, 3-car attached garage, covered porch, geothermal heating and 2.75[±] acre pond. Also has 1,680 sq. ft. heated shop with 3 overhead doors.

Owner: Dixie Snider Estate

Auction Terms & Conditions:

PROCEDURE: The property will be offered in 6 individual tracts, any combination of tracts and as a total 79[±] acre unit. There will be open bidding on all tracts and combinations during the auction as determined by the Auctioneer. Bids on tracts, tract combinations and the total property may compete.

DOWN PAYMENT: 10% down payment on the day of auction for individual tracts or combinations of tracts. The down payment may be made in the form of cashier's check, personal check, or corporate check. **YOUR BIDDING IS NOT CONDITIONAL UPON FINANCING**, so be sure you have arranged financing, if needed, and are capable of paying cash at closing.

ACCEPTANCE OF BID PRICES: All successful bidders will be required to enter into Purchase Agreements at the auction site immediately following the close of the auction. All final bid prices are subject to the Sellers' acceptance or rejection.

EVIDENCE OF TITLE: Seller shall provide an owner's title insurance policy in the amount of the purchase price.

DEED: Seller shall provide Personal Representative Deed(s).

CLOSING: The targeted closing date will be approximately 30 days after the auction.

POSSESSION: Possession is at closing, subject to tenants rights.

REAL ESTATE TAXES: Real estate taxes will be prorated to the date of closing. Buyer(s) will be responsible beginning with taxes due in 2027 and thereafter.

PROPERTY INSPECTION: Each potential Bidder is responsible for conducting, at their own risk, their own independent inspections, investigations, inquiries and due diligence concerning the property. Inspection dates have been scheduled and will be staffed with auction personnel. Further, Seller disclaims any and all responsibility for Bidder's safety during any physical inspection of the property. No party shall be deemed an invitee of the property by virtue of the offering of the property for sale.

ACREAGE: All tract acreages, dimensions, and proposed boundaries are approximate and have been estimated based on current legal descriptions and/or aerial photos.

SURVEY: The Seller shall provide a new survey where there is no existing legal description or where new boundaries are created by the tract divisions in this auction. Any need for a new survey shall be determined solely by the Seller. Seller and successful bidder shall each pay half (50:50) of the cost of the survey. The type of survey performed shall be at the Seller's option and sufficient for providing title insurance. Combination purchases will receive a perimeter survey only.

AGENCY: Schrader Real Estate & Auction Company, Inc. and its representatives are exclusive agents of the Seller.

DISCLAIMER AND ABSENCE OF WARRANTIES:

All information contained in this brochure and all related materials are subject to the terms and conditions outlined in the Purchase Agreement. The property is being sold on an "AS IS, WHERE IS" basis, and no warranty or representation, either expressed or implied, concerning the property is made by the Seller or the Auction Company. All sketches and dimensions in the brochure are approximate. Each potential bidder is responsible for conducting his or her own independent inspections, investigations, inquiries, and due diligence concerning the property. The information contained in this brochure is subject to verification by all parties relying on it. No liability for its accuracy, errors, or omissions is assumed by the Seller or the Auction Company. Conduct of the auction and increments of bidding are at the direction and discretion of the Auctioneer. The Seller and Selling Agents reserve the right to preclude any person from bidding if there is any question as to the person's credentials, fitness, etc. All decisions of the Auctioneer are final. **ANY ANNOUNCEMENTS MADE THE DAY OF THE SALE TAKE PRECEDENCE OVER PRINTED MATERIAL OR ANY OTHER ORAL STATEMENTS MADE.**

Auction Managers:

Al Pfister • 260.760.8922

Mike Roy • 260.437.5428

800.451.2709 • SchraderAuction.com



SOILS MAP

SOILS MAP

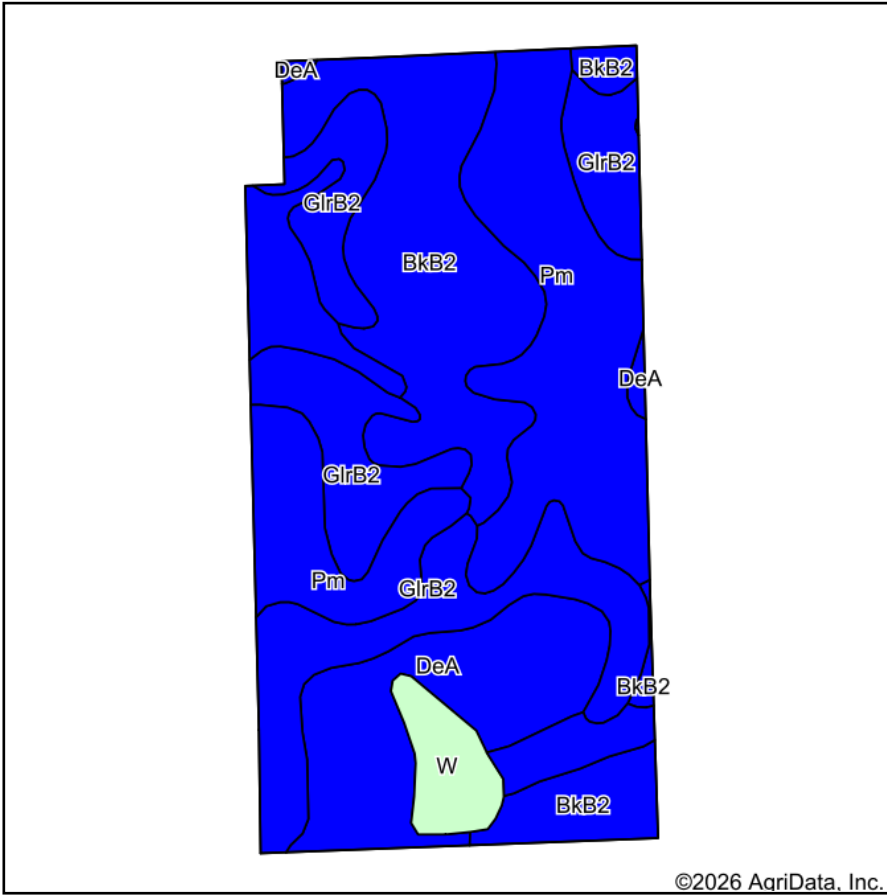

Soils data provided by USDA and NRCS.

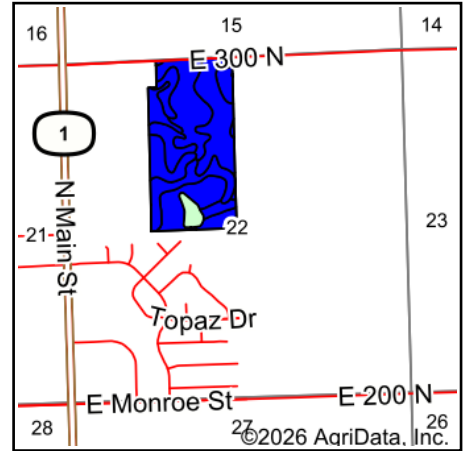

State: **Indiana**
 County: **Wells**
 Location: **22-27N-12E**
 Township: **Lancaster**
 Acres: **79.65**
 Date: **3/24/2026**



Maps Provided By

 CUSTOMIZED ONLINE MAPPING
 © AgriData, Inc. 2025 www.AgriDataInc.com



Area Symbol: IN179, Soil Area Version: 30

Code	Soil Description	Acres	Percent of field	Non-Irr Class Legend	Non-Irr Class	Corn Bu	Grass legume hay Tons	Grass legume pasture AUM	Pasture AUM	Soybeans Bu	Winter wheat Bu
Pm	Pewamo silty clay loam, 0 to 1 percent slopes	26.26	33.0%		llw	157	5	11		47	64
GlrB2	Glynwood silt loam, end moraine, 2 to 6 percent slopes, eroded	19.99	25.1%		lle	128	4	8		44	57
BkB2	Blount-Del Rey silt loams, 1 to 4 percent slopes, eroded	19.55	24.5%		lle	122	5		8	40	55
DeA	Del Rey-Blount silt loams, 0 to 1 percent slopes	11.05	13.9%		llw	126	5		8	41	57
W	Water	2.80	3.5%								
Weighted Average					*-	131.3	4.6	5.6	3.1	42	56.8

*- Non Irr Class weighted average cannot be calculated on the current soils data due to missing data.

TOPOGRAPHY MAP

TOPOGRAPHY MAP

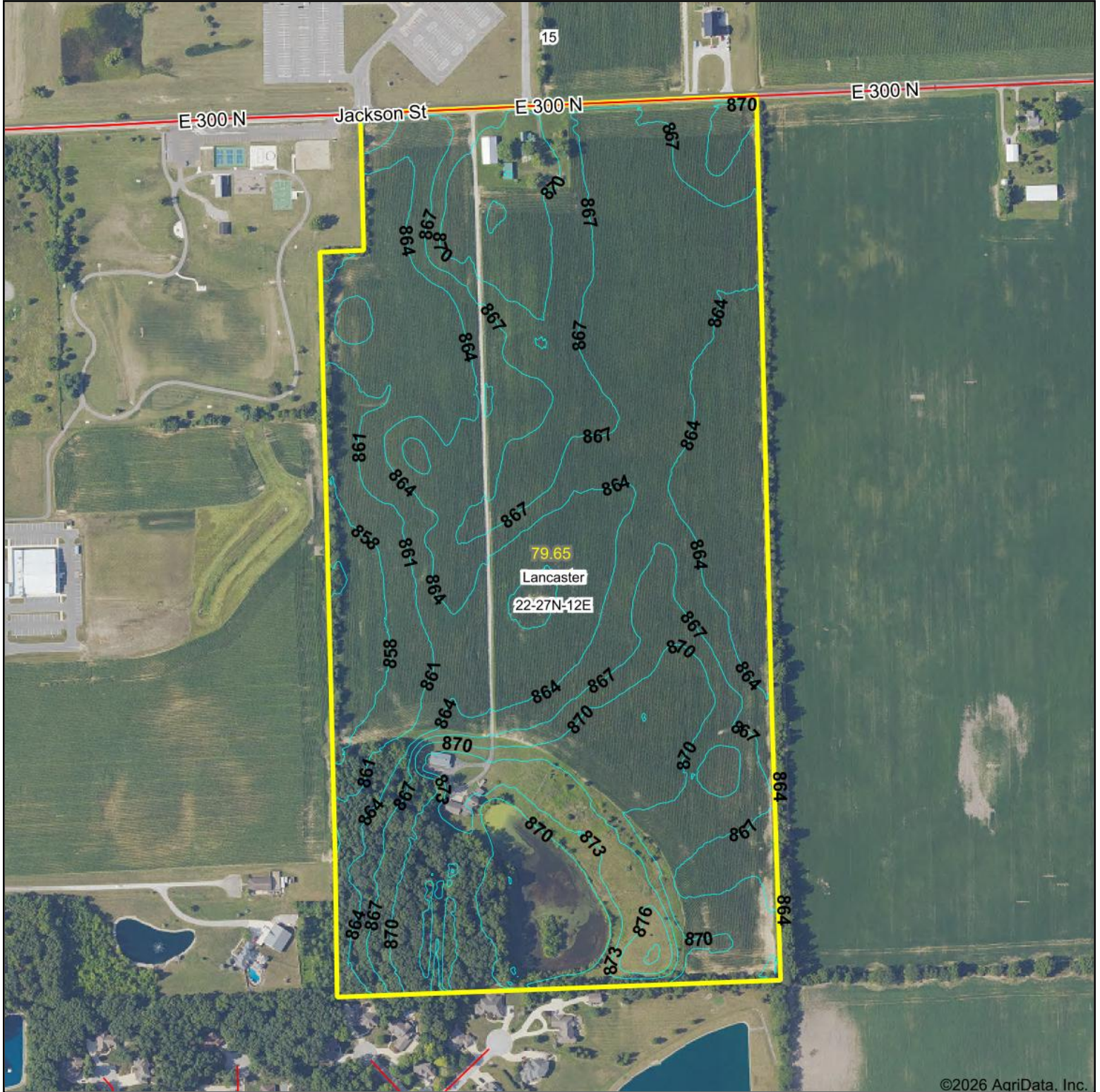

©2026 AgriData, Inc.



© AgriData, Inc. 2025 www.AgriDataInc.com

Source: USGS 1 meter dem

Interval(ft): 3.0

Min: 853.0

Max: 879.3

Range: 26.3

Average: 866.3

Standard Deviation: 4.13 ft

0ft 469ft 938ft



3/24/2026

22-27N-12E
Wells County
Indiana

Boundary Center: 40° 46' 57.04, -85° 9' 31.45

ZONING MAP

ZONING MAP

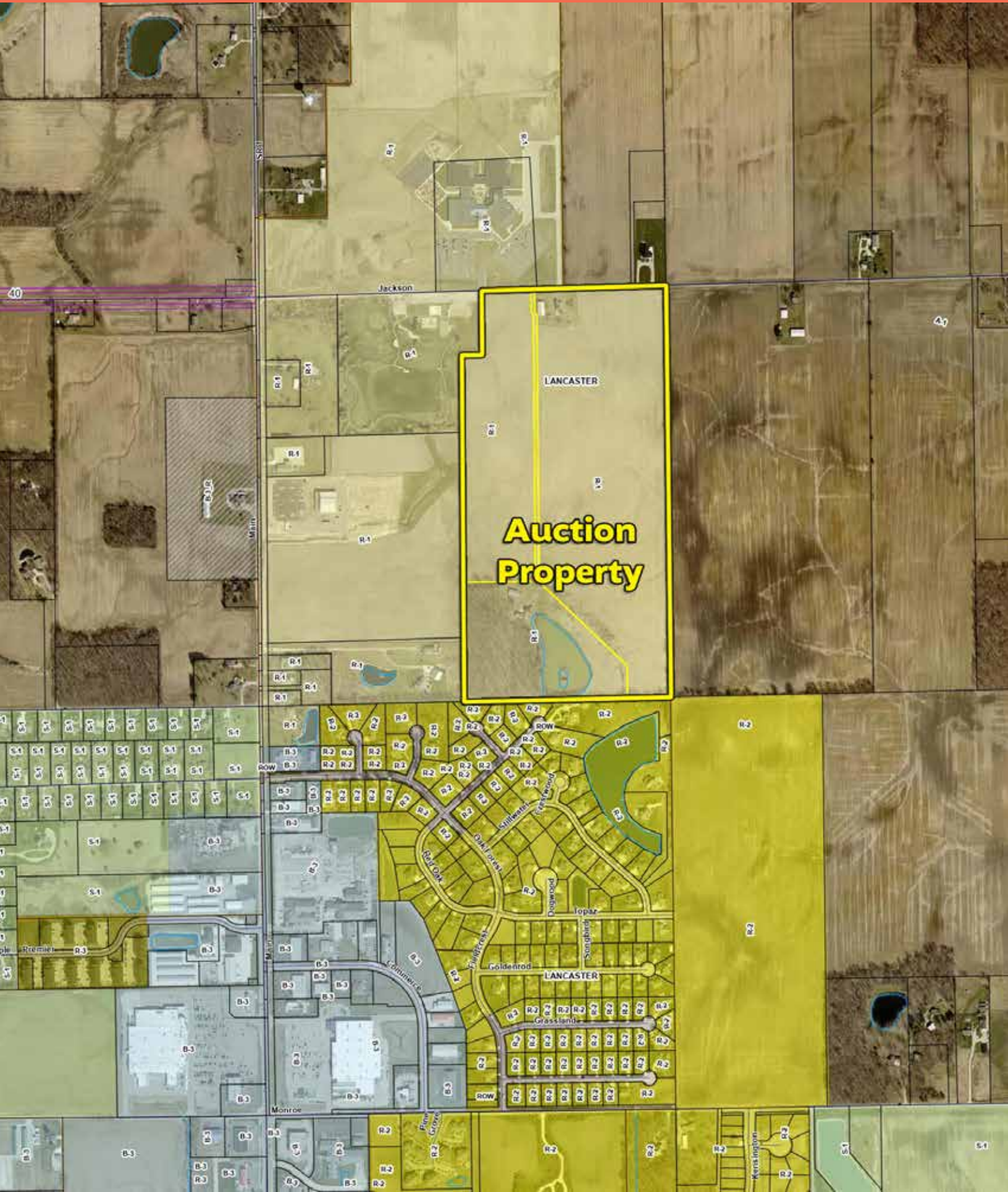



COUNTY PROPERTY REPORTS

COUNTY PROPERTY REPORT

TRACTS 1-5

Wells County, IN

Tax Statements

Tax Statements are a duplicate copy of the original mailing.
This statement does not update with payments or corrections.

- [2026 Tax Statement \(PDF\)](#)
- [2025 Tax Statement \(PDF\)](#)
- [2024 Tax Statement \(PDF\)](#)
- [2023 Tax Statement \(PDF\)](#)
- [2022 Tax Statement \(PDF\)](#)
- [2021 Tax Statement \(PDF\)](#)
- [2020 Tax Statement \(PDF\)](#)

Pay Taxes Online

To make a payment by check or use a credit or debit card payment online, please click here

[Pay Taxes Online](#)

There is a 2.5% fee for credit card service and a flat fee of \$4.00 for any debit card. Please print or record your transaction number for future reference.
Electronic check payments will incur a \$1.75 flat rate fee.

Summary

Parcel ID 90-05-22-200-004.000-011
 Bill ID 012-03196-00
 Reference #
 Property Address 370 E Jackson
 Bluffton, IN, 46714
 Brief Legal Description 22-27-12 63.00A PT E NW
 (Note: Not to be used on legal documents)
 Instrument Nbr N/A
 Doc Nbr N/A
 Class AGRICULTURAL - CASH GRAIN/GENERAL FARM
 Tax District Bluffton City - Lancaster NW
 Tax Rate Code 977918 - Adv. Tax Rate
 Property Type 65 - Agricultural
 Mortgage Co N/A
 Last Change Date



Owners

Deeded Owner
[Snider, Dixie L](#)
 C/O Snider, Michael
 1115 Almdale Dr
 Fort Wayne, IN 46818

Taxing District

County: Wells
 Township: LANCASTER TOWNSHIP
 State District 011 BLUFFTON CITY-LANCASTER TWP-N
 Local District: 011
 School Corp: NORTHERN WELLS COMMUNITY
 Neighborhood: 502947-011 LANCASTER TOWNSHIP PAVED 011

Site Description

Topography: Flat, Rolling
 Public Utilities: Electricity
 Street or Road: Paved
 Area Quality:
 Parcel Acreage: 63

Refer to Brief Tax Description for Parcel Acreage.

Land

Land Type	Soil ID	Act Front.	Eff. Depth	Size	Rate	Adj. Rate	Ext. Value	Infl. %	Value
Homesite		0	0	1.0000	\$41,000.00	\$41,000.00	\$41,000.00	(47%)	\$21,730.00
Road Right of Way		0	0	.65	\$2,120.00	\$2,120.00	\$1,378.00	(100%)	\$0.00
Land Used by Farm Buildings	BKB2	0	0	.04	\$2,120.00	\$1,887.00	\$75.48	(40%)	\$50.00
Tillable Cropland	BKB2	0	0	16.01	\$2,120.00	\$1,887.00	\$30,210.87	0%	\$30,210.00
Tillable Cropland	DEA	0	0	4.44	\$2,120.00	\$1,887.00	\$8,378.28	0%	\$8,380.00
Tillable Cropland	GNB2	0	0	16.09	\$2,120.00	\$1,632.00	\$26,258.88	0%	\$26,260.00
Tillable Cropland	PM	0	0	24.77	\$2,120.00	\$2,353.00	\$58,283.81	0%	\$58,280.00

COUNTY PROPERTY REPORT

TRACTS 1-5

Residential Dwellings

Description	Single-Family
Story Height	2
Style	64 Two Story - Before 1950
Finished Area	1416
# Fireplaces	0
Heat Type	Other
Air Cond	0
Bedrooms	3
Living Rooms:	1
Dining Rooms:	0
Family Rooms:	0
Finished Rooms:	5
Full Baths	1
Full Bath Fixtures	3
Half Baths	0
Half Bath Fixtures	0
Kitchen Sinks	1
Water Heaters	1
Add Fixtures	0

Floor	Construction	Base	Finish
1	Wood Frame	952	952
2	Wood Frame	464	464
C		952	0

Features	Area
Porch, Enclosed Frame	168
Stoop, Masonry	35

Improvements

Descr	PC	Grade	Year Built	Eff Year	Cond	LCM	Size	Nbhd Factor	Mrkt Factor
Single-Family	100	D+2	1900	1970	A	1.01	1416	1.39	0.47
Detached Garage	100	D	1900	1900	A	1.01	280	1.39	0
Utility Shed	100	D	1900	1900	A	1.01	360	1.39	0
Barn, Pole (T3) 1	100	C	1900	1900	A	1.01	1152	1.39	0
Barn, Pole (T3) 2	100	C	1984	1984	A	1.01	3402	1.39	0

Transfers

Date	New Owner	Doc ID	Book/Page	Sale Price
2/11/1999	Snider, Dixie L	0	135/307	\$0.00
	15.75A TO SNIDER, EDWIN L/DIXIE L			\$0.00



[Click here to access the digital deed records for Wells County](#)

Valuation

Assessment Year	2025	2025 (2)	2024	2023	2022
Reason	Annual Adjustment	Annual Adjustment	Annual Adjustment	MISCELLANEOUS	Annual Adjustment
As Of Date	5/30/2025	4/13/2025	3/30/2024	7/2/2023	4/7/2022
Land	\$144,900	\$160,500	\$152,100	\$144,300	\$112,200
Land Res (1)	\$0	\$0	\$0	\$0	\$0
Land Non Res (2)	\$144,900	\$160,500	\$152,100	\$144,300	\$112,200
Land Non Res (3)	\$0	\$0	\$0	\$0	\$0
Improvement	\$84,300	\$84,300	\$75,600	\$117,900	\$115,900
Imp Res (1)	\$34,000	\$34,000	\$31,500	\$31,500	\$0
Imp Non Res (2)	\$50,300	\$50,300	\$44,100	\$86,400	\$86,500
Imp Non Res (3)	\$0	\$0	\$0	\$0	\$29,400
Total	\$229,200	\$244,800	\$227,700	\$262,200	\$228,100
Total Res (1)	\$34,000	\$34,000	\$31,500	\$31,500	\$0
Total Non Res (2)	\$195,200	\$210,800	\$196,200	\$230,700	\$198,700
Total Non Res (3)	\$0	\$0	\$0	\$0	\$29,400

Tax History

COUNTY PROPERTY REPORT

TRACTS 1-5

Delinquent payments made between May 11 and June 10 will have a 5% penalty. Delinquent payments made after June 10 will have a 10% (total) penalty.

	2025 Pay 2026	2024 Pay 2025	2023 Pay 2024	2022 Pay 2023	2021 Pay 2022
+ Spring Tax	\$2,045.46	\$2,040.16	\$2,380.93	\$1,936.55	\$1,640.03
+ Spring Penalty	\$0.00	\$0.00	\$0.00	\$0.00	\$164.00
+ Spring Annual	\$0.00	\$0.00	\$0.00	\$0.00	\$0.00
+ Fall Tax	\$2,045.46	\$2,040.16	\$2,380.93	\$1,936.55	\$1,640.03
+ Fall Penalty	\$0.00	\$0.00	\$0.00	\$0.00	\$164.00
+ Fall Annual	\$0.00	\$0.00	\$0.00	\$0.00	\$0.00
+ Delq NTS Tax	\$0.00	\$0.00	\$0.00	\$1,640.03	\$0.00
+ Delq NTS Pen	\$0.00	\$0.00	\$0.00	\$164.00	\$0.00
+ Delq TS Tax	\$0.00	\$0.00	\$0.00	\$1,640.03	\$0.00
+ Delq TS Pen	\$0.00	\$0.00	\$0.00	\$164.00	\$0.00
+ Other Assess	\$44.28	\$44.28	\$44.28	\$92.98	\$48.70
<hr/>					
+ Advert Fee	\$0.00	\$0.00	\$0.00	\$0.00	\$0.00
+ Tax Sale Fee	\$0.00	\$0.00	\$0.00	\$0.00	\$0.00
+ NSF Fee	\$0.00	\$0.00	\$0.00	\$0.00	\$0.00
<hr/>					
PTRC	\$0.00	\$0.00	\$0.00	\$0.00	\$0.00
HMST Credit	\$0.00	\$0.00	\$0.00	\$0.00	\$0.00
Circuit Breaker	\$0.00	\$0.00	\$0.00	\$0.00	\$0.00
Over 65 CB	\$0.00	\$0.00	\$0.00	\$0.00	\$0.00
<hr/>					
= Charges	\$4,135.20	\$4,124.60	\$4,806.14	\$7,574.14	\$3,656.76
- Surplus Transfer	\$0.00	\$0.00	\$0.00	\$0.00	\$0.00
- Credits		(\$4,124.60)	(\$4,806.14)	(\$7,574.14)	
= Total Due	\$4,135.20	\$0.00	\$0.00	\$0.00	\$3,656.76

Deductions

Type	Description	2025 Pay 2026
Other	2% Deduction	\$13,752.00

Other Assessments

Tax Year	Number	Name	Acreage	Rate Code	Rate/Acre	Minimum	Amount
2024 Pay 2025	1167047	502 JOHNSON	44.28	ADV Rate	1	15	44.28
2023 Pay 2024	1167047	502 JOHNSON	44.28	ADV Rate	1	15	44.28
2022 Pay 2023	1167047	502 JOHNSON	44.28	ADV Rate	1	15	92.98
2021 Pay 2022	1167047	502 JOHNSON	44.28	ADV Rate	1	15	48.7
2020 Pay 2021	1167047	502 JOHNSON	44.28	ADV Rate	1	15	44.28

Photos



COUNTY PROPERTY REPORT

TRACTS 1-5



Sketches

COUNTY PROPERTY REPORT

TRACTS 1-5

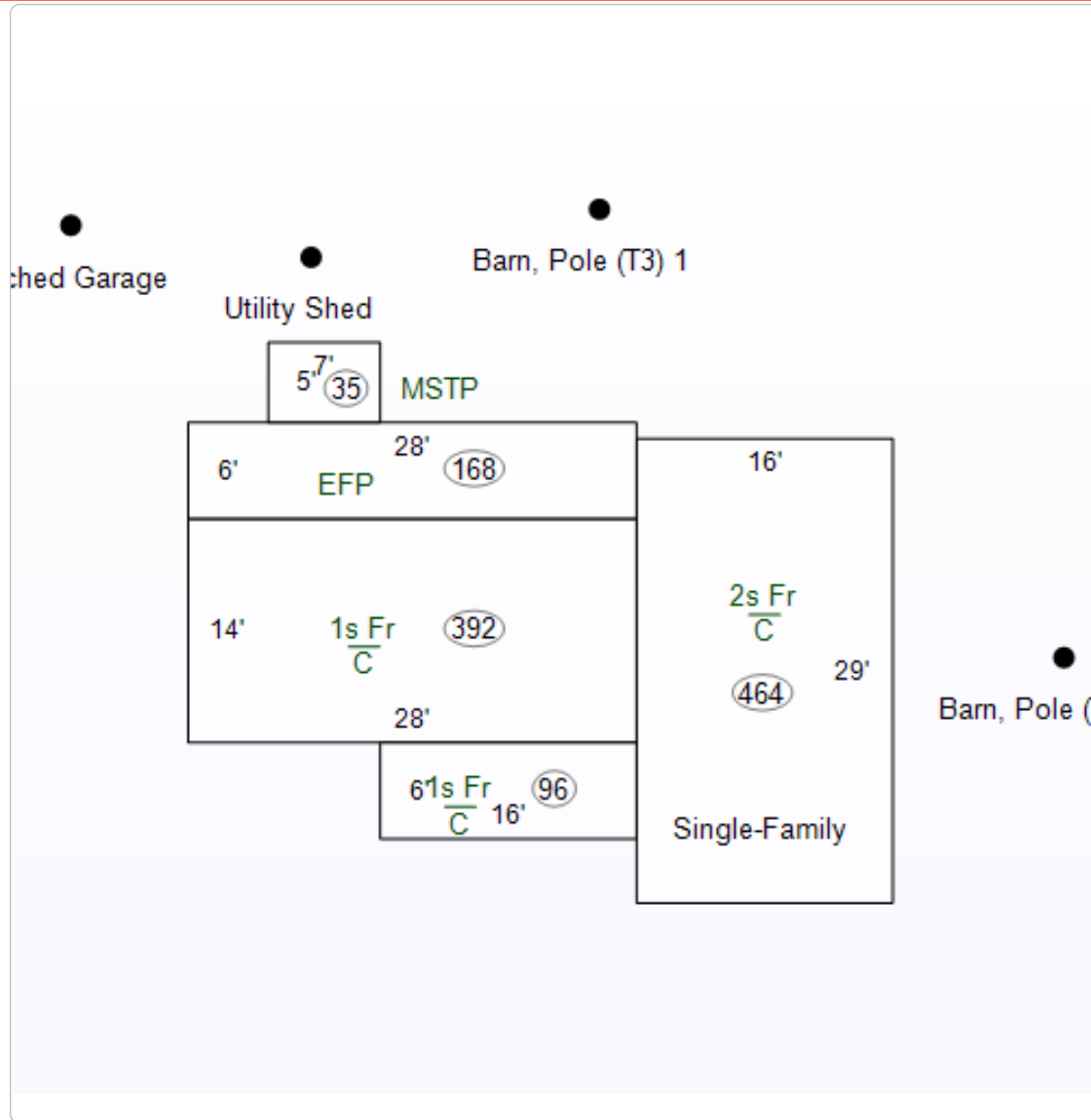

Property Record Cards

[2025 Property Record Card \(PDF\)](#)

[2024 Property Record Card \(PDF\)](#)

[2023 Property Record Card \(PDF\)](#)

Form 11

To receive and view your Form 11 online please visit

enoticesonline.com

You can log in to an account you already created or create a new account to view or print

your Form 11 anytime for free.

Once the budgets for local units are certified, anyone interested in estimating their property tax bill may do so using the DLGF's online property tax calculator at www.in.gov/dlgf/4932.htm. Individuals will need their property's assessed value, deductions, and taxing district to use the tool. The ESTIMATES provided are PROJECTIONS ONLY and SHOULD NOT be taken as a statement of true tax liability, which is determined by the county.

No data available for the following modules: Transfer History.

Neither Wells County Government nor any of its employees makes any representation or any warranty, neither expressed or implied, or assumes any legal liability or responsibility for the accuracy, completeness, or usefulness of any information, nor claims it as a legal information source

| [User Privacy Policy](#) | [GDPR Privacy Notice](#)

Last Data Upload: 4/24/2026, 10:29:31 PM

Contact Us

Developed by
 SCHNEIDER
 GEOSPATIAL

COUNTY PROPERTY REPORT

TRACT 6

Wells County, IN

Tax Statements

Tax Statements are a duplicate copy of the original mailing.
This statement does not update with payments or corrections.

- [2026 Tax Statement \(PDF\)](#)
- [2025 Tax Statement \(PDF\)](#)
- [2024 Tax Statement \(PDF\)](#)
- [2023 Tax Statement \(PDF\)](#)
- [2022 Tax Statement \(PDF\)](#)
- [2021 Tax Statement \(PDF\)](#)
- [2020 Tax Statement \(PDF\)](#)

Pay Taxes Online

To make a payment by check or use a credit or debit card payment online, please click here

[Pay Taxes Online](#)

There is a 2.5% fee for credit card service and a flat fee of \$4.00 for any debit card. Please print or record your transaction number for future reference.
Electronic check payments will incur a \$1.75 flat rate fee.

Summary

Parcel ID 90-05-22-200-005.000-011
 Bill ID 012-03196-01
 Reference #
 Property Address 350 E Jackson
 Bluffton, IN, 46714
 Brief Legal Description 22-27-12 15.75A W PT E/2 NW
 (Note: Not to be used on legal documents)
 Instrument Nbr N/A
 Doc Nbr N/A
 Class RESIDENTIAL ONE FAMILY DWELLING ON UNPLATTED LAND OF
 10-19.99 ACRES
 Tax District Bluffton City - Lancaster NW
 Tax Rate Code 977918 - Adv. Tax Rate
 Property Type 65 - Agricultural
 Mortgage Co N/A
 Last Change Date



Owners

Deeded Owner
 Snider, Edwin L / Dixie L
 C/O Snider, Michael
 1115 Almdale Dr
 Fort Wayne, IN 46818

Taxing District

County: Wells
 Township: LANCASTER TOWNSHIP
 State District 011 BLUFFTON CITY-LANCASTER TWP-N
 Local District: 011
 School Corp: NORTHERN WELLS COMMUNITY
 Neighborhood: 502947-011 LANCASTER TOWNSHIP PAVED 011

Site Description

Topography: Flat, Rolling
 Public Utilities: Electricity
 Street or Road: Paved
 Area Quality:
 Parcel Acreage: 15.75
 Refer to Brief Tax Description for Parcel Acreage.

Land

Land Type	Soil ID	Act Front.	Eff. Depth	Size	Rate	Adj. Rate	Ext. Value	Infl. %	Value
Homesite		0	0	1.0000	\$41,000.00	\$41,000.00	\$41,000.00	0%	\$41,000.00
Residential Excess Acreage		0	0	14.74	\$15,450.00	\$15,450.00	\$227,733.00	0%	\$79,760.00
Road Right of Way		0	0	.01	\$2,120.00	\$2,120.00	\$21.20	(100%)	\$0.00

Residential Dwellings

COUNTY PROPERTY REPORT

TRACT 6

Description	Single-Family
Story Height	1
Style	41 One Story Newer Style
Finished Area	2021
# Fireplaces	2
Heat Type	Central Warm Air
Air Cond	2021
Bedrooms	3
Living Rooms:	1
Dining Rooms:	0
Family Rooms:	0
Finished Rooms:	5
Full Baths	3
Full Bath Fixtures	9
Half Baths	0
Half Bath Fixtures	0
Kitchen Sinks	1
Water Heaters	1
Add Fixtures	1

Floor	Construction	Base	Finish
1	1/6 Masonry	2021	2021
B		2021	0

Features	Area
Porch, Enclosed Frame	323
Porch, Enclosed Frame	45
Porch, Open Frame	180
Porch, Open Frame	16
Porch, Open Frame	96
Wood Deck	96
Wood Deck	99

Improvements

Descr	PC	Grade	Year Built	Eff Year	Cond	LCM	Size	Nbhd Factor	Mrkt Factor
Single-Family	100	B-1	2000	2000	A	1.01	2021	1.39	1.1
Detached Garage	100	C	2004	2004	A	1.01	1680	1.39	1
Utility Shed	100	D	2008	2008	A	1.01	96	1.39	1

Transfers

Date	New Owner	Doc ID	Book/Page	Sale Price
2/11/1999	Snider, Edwin L / Dixie L	0	135/307	\$0.00
	SNIDER, DIXIE L			\$0.00



[Click here to access the digital deed records for Wells County](#)

Valuation

Assessment Year	2025	2025 (2)	2024	2023	2022
Reason	Annual Adjustment	Annual Adjustment	Annual Adjustment	MISCELLANEOUS	Annual Adjustment
As Of Date	5/30/2025	4/13/2025	3/30/2024	7/2/2023	4/7/2022
Land	\$120,800	\$120,800	\$112,300	\$104,500	\$78,400
Land Res (1)	\$41,000	\$41,000	\$37,000	\$33,900	\$25,000
Land Non Res (2)	\$79,800	\$79,800	\$75,300	\$70,600	\$0
Land Non Res (3)	\$0	\$0	\$0	\$0	\$53,400
Improvement	\$515,200	\$515,200	\$445,100	\$418,900	\$406,400
Imp Res (1)	\$515,200	\$515,200	\$445,100	\$418,900	\$393,200
Imp Non Res (2)	\$0	\$0	\$0	\$0	\$0
Imp Non Res (3)	\$0	\$0	\$0	\$0	\$13,200
Total	\$636,000	\$636,000	\$557,400	\$523,400	\$484,800
Total Res (1)	\$556,200	\$556,200	\$482,100	\$452,800	\$418,200
Total Non Res (2)	\$79,800	\$79,800	\$75,300	\$70,600	\$0
Total Non Res (3)	\$0	\$0	\$0	\$0	\$66,600

COUNTY PROPERTY REPORT

TRACT 6

Tax History

Delinquent payments made between May 11 and June 10 will have a 5% penalty. Delinquent payments made after June 10 will have a 10% (total) penalty.

	2025 Pay 2026	2024 Pay 2025	2023 Pay 2024	2022 Pay 2023	2021 Pay 2022
+ Spring Tax	\$5,675.89	\$4,994.22	\$4,752.78	\$4,117.56	\$2,736.20
+ Spring Penalty	\$0.00	\$0.00	\$0.00	\$0.00	\$273.62
+ Spring Annual	\$0.00	\$0.00	\$0.00	\$0.00	\$0.00
+ Fall Tax	\$5,675.89	\$4,994.22	\$4,752.78	\$4,117.56	\$2,736.20
+ Fall Penalty	\$0.00	\$0.00	\$0.00	\$0.00	\$273.62
+ Fall Annual	\$0.00	\$0.00	\$0.00	\$0.00	\$0.00
+ Delq NTS Tax	\$0.00	\$0.00	\$0.00	\$2,736.20	\$0.00
+ Delq NTS Pen	\$0.00	\$0.00	\$0.00	\$273.62	\$0.00
+ Delq TS Tax	\$0.00	\$0.00	\$0.00	\$2,736.20	\$0.00
+ Delq TS Pen	\$0.00	\$0.00	\$0.00	\$273.62	\$0.00
+ Other Assess	\$15.00	\$15.00	\$15.00	\$31.50	\$16.50
+ Advert Fee	\$0.00	\$0.00	\$0.00	\$0.00	\$0.00
+ Tax Sale Fee	\$0.00	\$0.00	\$0.00	\$0.00	\$0.00
+ NSF Fee	\$0.00	\$0.00	\$0.00	\$0.00	\$0.00
PTRC	\$0.00	\$0.00	\$0.00	\$0.00	\$0.00
HMST Credit	\$0.00	\$0.00	\$0.00	\$0.00	\$0.00
Circuit Breaker	\$0.00	\$0.00	\$0.00	\$0.00	\$0.00
Over 65 CB	\$0.00	\$0.00	\$0.00	\$0.00	\$0.00
= Charges	\$11,366.78	\$10,003.44	\$9,520.56	\$14,286.26	\$6,036.14
- Surplus Transfer	\$0.00	\$90.00	\$0.00	\$0.00	\$0.00
- Credits		(\$10,093.44)	(\$9,520.56)	(\$14,286.26)	
= Total Due	\$11,366.78	(\$90.00)	\$0.00	\$0.00	\$6,036.14

Deductions

Type	Description	2025 Pay 2026
Other	2% Deduction	\$38,160.00

Other Assessments

Tax Year	Number	Name	Acreage	Rate Code	Rate/Acre	Minimum	Amount
2024 Pay 2025	1167047	502 JOHNSON	7.53	ADV Rate	1	15	15
2023 Pay 2024	1167047	502 JOHNSON	7.53	ADV Rate	1	15	15
2022 Pay 2023	1167047	502 JOHNSON	7.53	ADV Rate	1	15	31.5
2021 Pay 2022	1167047	502 JOHNSON	7.53	ADV Rate	1	15	16.5
2020 Pay 2021	1167047	502 JOHNSON	7.53	ADV Rate	1	15	15

Photos



COUNTY PROPERTY REPORT

TRACT 6



Sketches

COUNTY PROPERTY REPORT

TRACT 6

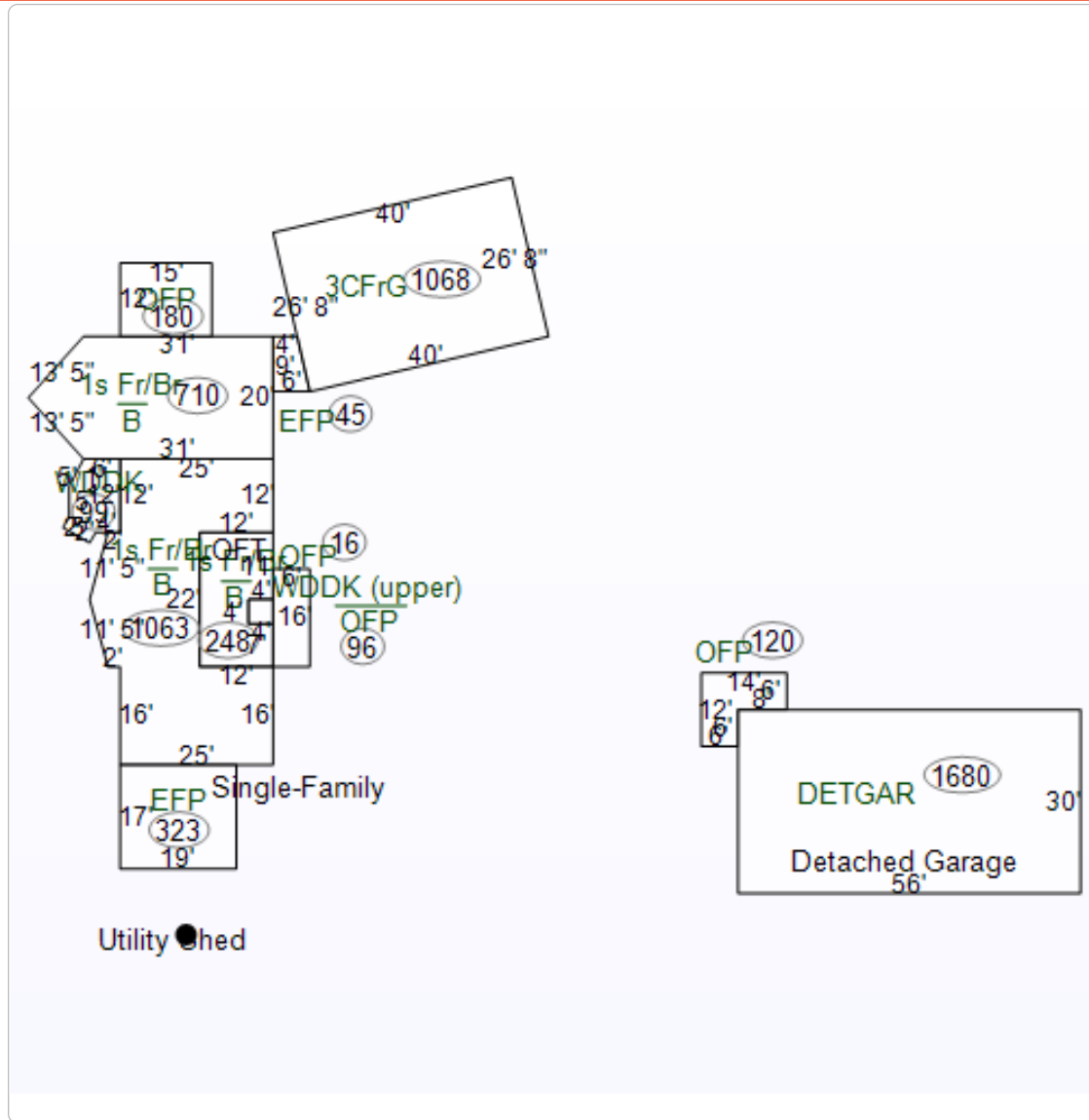

Property Record Cards

- [2025 Property Record Card \(PDF\)](#)
- [2024 Property Record Card \(PDF\)](#)
- [2023 Property Record Card \(PDF\)](#)

Form 11

To receive and view your Form 11 online please visit enoticesonline.com You can log in to an account you already created or create a new account to view or print your Form 11 anytime for free.

Once the budgets for local units are certified, anyone interested in estimating their property tax bill may do so using the DLGF's online property tax calculator at www.in.gov/dlgf/4932.htm. Individuals will need their property's assessed value, deductions, and taxing district to use the tool. The ESTIMATES provided are PROJECTIONS ONLY and SHOULD NOT be taken as a statement of true tax liability, which is determined by the county.

No data available for the following modules: Transfer History.

Neither Wells County Government nor any of its employees makes any representation or any warranty, neither expressed or implied, or assumes any legal liability or responsibility for the accuracy, completeness, or usefulness of any information, nor claims it as a legal information source

| [User Privacy Policy](#) | [GDPR Privacy Notice](#)
Last Data Upload: 4/24/2026, 10:29:31 PM

Contact Us

Developed by
 SCHNEIDER
GEOSPATIAL

TAX STATEMENTS

TAX STATEMENT

TRACTS 1-5

STATE FORM 53569 (R27 / 01-26)
APPROVED BY STATE BOARD OF ACCOUNTS, 2025

TREASURER FORM TS-1A
PRESCRIBED BY THE DEPARTMENT OF LOCAL GOVERNMENT FINANCE IC 6-1.1-22-8.1

COUNTY: 90 - Wells

SPRING INSTALLMENT REMITTANCE COUPON

PARCEL NUMBER 90-05-22-200-004.000-011	DUPLICATE NUMBER 1579829	TAX YEAR 2025 Payable 2026	Late Payment Penalty: 5% penalty after May 11, 2026, if there is no delinquent amount; 10% penalty for previous delinquency or if payment is made after June 10, 2026.
TAXING UNIT NAME Bluffton City - Lancaster NW	LEGAL DESCRIPTION 22-27-12 63.00A PT E NW		
PROPERTY ADDRESS 370 E Jackson, Bluffton IN 46714			SPRING AMOUNT DUE by May 11, 2026: \$ 2,067.60



12692*36**G50**0.574**1/4*****AUTO**ALL FOR AADC 467
SNIDER, DIXIE L
C/O SNIDER, MICHAEL
1115 ALMDALE DR
FORT WAYNE IN 46818-8428



Phone: (260)824-6512
Pay online at: www.wellscounty.org
Pay by phone: (877) 690-3729 Jurisdiction Code: 2438

Remit Payment and Make Check Payable to:
Wells County Treasurer
102 W Market St., Suite 204
Bluffton IN 46714

Please fold on perforation BEFORE tearing

3-25-26_V5

COUNTY: 90 - Wells

FALL INSTALLMENT REMITTANCE COUPON

PARCEL NUMBER 90-05-22-200-004.000-011	DUPLICATE NUMBER 1579829	TAX YEAR 2025 Payable 2026	Late Payment Penalty: 5% penalty after November 10, 2026, if there is no delinquent amount; 10% penalty for previous delinquency or if payment is made after December 10, 2026.
TAXING UNIT NAME Bluffton City - Lancaster NW	LEGAL DESCRIPTION 22-27-12 63.00A PT E NW		
PROPERTY ADDRESS 370 E Jackson, Bluffton IN 46714			FALL AMOUNT DUE by November 10, 2026: \$ 2,067.60



SNIDER, DIXIE L
C/O SNIDER, MICHAEL
1115 ALMDALE DR
FORT WAYNE IN 46818

Phone: (260)824-6512
Pay online at: www.wellscounty.org
Pay by phone: (877) 690-3729 Jurisdiction Code: 2438

Remit Payment and Make Check Payable to:
Wells County Treasurer
102 W Market St., Suite 204
Bluffton IN 46714

Please fold on perforation BEFORE tearing

COUNTY: 90 - Wells

TAXPAYERS' COPY - KEEP FOR YOUR RECORDS

PARCEL NUMBER 90-05-22-200-004.000-011	DUPLICATE NUMBER 1579829	TAX YEAR 2025 Payable 2026	DUE DATES SPRING - May 11, 2026 FALL - November 10, 2026
TAXING UNIT NAME Bluffton City - Lancaster NW	LEGAL DESCRIPTION 22-27-12 63.00A PT E NW		

DATE OF STATEMENT: 03/30/2026

TOTAL DUE FOR 25 PAY 26: \$4,135.20

PROPERTY ADDRESS 370 E Jackson, Bluffton IN 46714	
PROPERTY TYPE Real	TOWNSHIP Lancaster
ACRES 63.0000	

ITEMIZED CHARGES	SPRING TOTAL	FALL TOTAL
Tax	\$2,045.46	\$2,045.46
Delinquent Tax	\$0.00	\$0.00
Delinquent Penalty	\$0.00	\$0.00
Other Assessment(OA)	\$22.14	\$22.14
Delinquent OA Tax	\$0.00	\$0.00
Delinquent OA Penalty	\$0.00	\$0.00
Fees	\$0.00	\$0.00
Adjustments	\$0.00	\$0.00
Amount Due	\$2,067.60	\$2,067.60
Payment Received	(\$0.00)	(\$0.00)
Balance Due	\$2,067.60	\$2,067.60

SNIDER, DIXIE L
C/O SNIDER, MICHAEL
1115 ALMDALE DR
FORT WAYNE IN 46818

Scan the QR code for additional information about property tax deductions or contact the county auditor's office at: (260) 824-6470.



TAX STATEMENT

TRACT 6

STATE FORM 53569 (R27 / 01-26)
APPROVED BY STATE BOARD OF ACCOUNTS, 2025

TREASURER FORM TS-1A
PRESCRIBED BY THE DEPARTMENT OF LOCAL GOVERNMENT FINANCE IC 6-1.1-22-8.1

COUNTY: 90 - Wells

SPRING INSTALLMENT REMITTANCE COUPON

PARCEL NUMBER 90-05-22-200-005.000-011	DUPLICATE NUMBER 1579833	TAX YEAR 2025 Payable 2026	Late Payment Penalty: 5% penalty after May 11, 2026, if there is no delinquent amount; 10% penalty for previous delinquency or if payment is made after June 10, 2026.
TAXING UNIT NAME Bluffton City - Lancaster NW	22-27-12 15.75A	LEGAL DESCRIPTION W PT E/2 NW	
PROPERTY ADDRESS 350 E Jackson, Bluffton IN 46714			SPRING AMOUNT DUE by May 11, 2026: \$ 5,690.89



12693*36**G50**0.574**1/4*****AUTO**ALL FOR AACD 467
SNIDER, EDWIN L / DIXIE L
C/O SNIDER, MICHAEL
1115 ALMDALE DR
FORT WAYNE IN 46818-8428



Phone: (260)824-6512
Pay online at: www.wellscounty.org
Pay by phone: (877) 690-3729 Jurisdiction Code: 2438

Remit Payment and Make Check Payable to:
Wells County Treasurer
102 W Market St., Suite 204
Bluffton IN 46714

Please fold on perforation BEFORE tearing

3-25-26_V5

COUNTY: 90 - Wells

FALL INSTALLMENT REMITTANCE COUPON

PARCEL NUMBER 90-05-22-200-005.000-011	DUPLICATE NUMBER 1579833	TAX YEAR 2025 Payable 2026	Late Payment Penalty: 5% penalty after November 10, 2026, if there is no delinquent amount; 10% penalty for previous delinquency or if payment is made after December 10, 2026.
TAXING UNIT NAME Bluffton City - Lancaster NW	22-27-12 15.75A	LEGAL DESCRIPTION W PT E/2 NW	
PROPERTY ADDRESS 350 E Jackson, Bluffton IN 46714			FALL AMOUNT DUE by November 10, 2026: \$ 5,675.89



SNIDER, EDWIN L / DIXIE L
C/O SNIDER, MICHAEL
1115 ALMDALE DR
FORT WAYNE IN 46818

Phone: (260)824-6512
Pay online at: www.wellscounty.org
Pay by phone: (877) 690-3729 Jurisdiction Code: 2438

Remit Payment and Make Check Payable to:
Wells County Treasurer
102 W Market St., Suite 204
Bluffton IN 46714

Please fold on perforation BEFORE tearing

COUNTY: 90 - Wells

TAXPAYERS' COPY – KEEP FOR YOUR RECORDS

PARCEL NUMBER 90-05-22-200-005.000-011	DUPLICATE NUMBER 1579833	TAX YEAR 2025 Payable 2026	DUE DATES SPRING - May 11, 2026 FALL - November 10, 2026
TAXING UNIT NAME Bluffton City - Lancaster NW	22-27-12 15.75A	LEGAL DESCRIPTION W PT E/2 NW	

DATE OF STATEMENT: 03/30/2026

TOTAL DUE FOR 25 PAY 26: \$11,366.78

PROPERTY ADDRESS 350 E Jackson, Bluffton IN 46714	
PROPERTY TYPE Real	TOWNSHIP Lancaster
ACRES 15.7500	

ITEMIZED CHARGES	SPRING TOTAL	FALL TOTAL
Tax	\$5,675.89	\$5,675.89
Delinquent Tax	\$0.00	\$0.00
Delinquent Penalty	\$0.00	\$0.00
Other Assessment(OA)	\$15.00	\$0.00
Delinquent OA Tax	\$0.00	\$0.00
Delinquent OA Penalty	\$0.00	\$0.00
Fees	\$0.00	\$0.00
Adjustments	\$0.00	\$0.00
Amount Due	\$5,690.89	\$5,675.89
Payment Received	(\$0.00)	(\$0.00)
Balance Due	\$5,690.89	\$5,675.89

SNIDER, EDWIN L / DIXIE L
C/O SNIDER, MICHAEL
1115 ALMDALE DR
FORT WAYNE IN 46818

Scan the QR code for additional information about property tax deductions or contact the county auditor's office at: (260) 824-6470.



PRELIMINARY TITLE

PRELIMINARY TITLE

TRACTS 1-5



First American

**Commitment for Title Insurance
Indiana - 2021 v. 01.00 (07-01-2021)**

ANY PERSON WHO, WITH INTENT TO DEFRAUD OR KNOWING THAT HE IS FACILITATING A FRAUD AGAINST AN INSURER, SUBMITS AN APPLICATION OR FILES A CLAIM CONTAINING A FALSE OR DECEPTIVE STATEMENT IS GUILTY OF INSURANCE FRAUD.

Transaction Identification Data, for which the Company assumes no liability as set forth in Commitment Condition 5.e.:

Issuing Agent: Metropolitan Title of Indiana, LLC
Issuing Office: 117 S. Johnson St., Bluffton, IN 46714
Issuing Office File Number: 4035-281916
Property Address: 370 E. Jackson, Bluffton, IN 46714
Revision Number:



SCHEDULE A

1. Commitment Date: March 18, 2026 at 8:00 a.m.
2. Policy to be issued:
 - a. ALTA® Standard Owner's Policy
Proposed Insured: To Be Determined
Proposed Amount of Insurance: \$500.00
The estate or interest to be insured: See Item 3 below
 - b. ALTA® Standard Loan Policy
Proposed Insured: TBD - Lender, its successors and/or assigns that are defined as an insured in the Conditions of the policy, as their interests may appear
Proposed Amount of Insurance: \$500.00
The estate or interest to be insured: See Item 3 below
3. The estate or interest in the Land at the Commitment Date is:

Fee Simple
4. The Title is, at the Commitment Date, vested in:

Devises under the Last Will and Testament of Dixie L. Snider, deceased
5. The Land is described as follows:

Situated in the County of Wells, State of Indiana, is described as follows:

This page is only a part of a 2021 ALTA Commitment for Title Insurance issued by Metropolitan Title of Indiana, LLC on behalf of First American Title Insurance Company. This Commitment is not valid without the Notice; the Commitment to Issue Policy; the Commitment Conditions; Schedule A; Schedule B, Part I—Requirements; and Schedule B, Part II—Exceptions; and a counter-signature by the Company or its issuing agent that may be in electronic form.

Copyright 2021 American Land Title Association. All rights reserved.

The use of this Form (or any derivative thereof) is restricted to ALTA licensees and ALTA members in good standing as of the date of use. All other uses are prohibited.
Reprinted under license from the American Land Title Association.

Form 50115218 (8-11-22)

Page 1 of 11

PRELIMINARY TITLE

TRACTS 1-5



First American

Commitment for Title Insurance
Indiana - 2021 v. 01.00 (07-01-2021)

The east half (1/2) of the northwest quarter (1/4) of section twenty-two (22) in township twenty-seven (27) north, range twelve (12) east, containing eighty (80) acres, more or less, excepting therefrom the following described real estate being a part of the east half (1/2) of the northwest quarter (1/4) of section twenty-two (22) in township twenty-seven (27) north, range twelve (12) east bounded and described as follows, to-wit: Commencing at the northwest corner of said east half (1/2) of the northwest quarter (1/4) of section twenty-two (22) and running thence south along the west line of said east half (1/2) of the northwest quarter (1/4) twenty-five (25) rods, thence east eight (8) rods, thence north twenty-five (25) rods to the north line of said northwest quarter of section twenty-two (22), thence west 8 rods to the place of beginning, said exception containing one and twenty-five hundredths acres.

Containing in all 78.75 acres, more or less.

EXCEPT THEREFROM:

Part of the Northwest Quarter of Section 22, Township 27 North, Range 12 East, Lancaster Township, Wells County, Indiana, described as follows:

Starting at the Northeast corner of said Northwest Quarter found per record witness; thence Westerly, 853.74 feet along the North line of said Northwest Quarter to the place of beginning; thence Southerly, deflecting left 89 degrees 13 minutes 00 seconds, 162.00 feet; thence Southeasterly, deflecting left 23 degrees 53 minutes 20 seconds, 30.00 feet; thence Southerly, deflecting right 24 degrees 37 minutes 18 seconds, 1729.47 feet; thence Easterly, deflecting left 87 degrees 58 minutes 56 seconds, 11.90 feet; thence Southeasterly, deflecting right 42 degrees 07 minutes 15 seconds, 742.23 feet; thence Southerly, deflecting right 42 degrees 49 minutes 06 seconds, 218.51 feet to the South line of said Northwest Quarter; thence Westerly, deflecting right 92 degrees 39 minutes 43 seconds, 1056.00 feet along said South line to a concrete post at the Southwest corner of the East half of said Northwest Quarter; thence Northerly, deflecting right 90 degrees 42 minutes 58 seconds, 760.00 feet along the West line of said East half; thence Easterly, deflecting right 91 degrees 41 minutes 00 seconds, 470.67 feet; thence Northerly, deflecting left 92 degrees 01 minutes 04 seconds, 1728.25 feet; thence northwesterly, deflecting left 24 degrees 37 minutes 18 seconds, 30.00 feet; thence Northerly, deflecting right 24 degrees 37 minutes 18 seconds, 162.00 feet to the North line of said Northwest Quarter; thence Easterly, deflecting right 89 degrees 13 minutes 00 seconds, 25.00 feet along said North line to the place of beginning.
CONTAINING 15.75 ACRES.

This page is only a part of a 2021 ALTA Commitment for Title Insurance issued by Metropolitan Title of Indiana, LLC on behalf of First American Title Insurance Company. This Commitment is not valid without the Notice; the Commitment to Issue Policy; the Commitment Conditions; Schedule A; Schedule B, Part I—Requirements; and Schedule B, Part II—Exceptions; and a counter-signature by the Company or its issuing agent that may be in electronic form.

Copyright 2021 American Land Title Association. All rights reserved.

The use of this Form (or any derivative thereof) is restricted to ALTA licensees and ALTA members in good standing as of the date of use. All other uses are prohibited.
Reprinted under license from the American Land Title Association.

Form 50115218 (8-11-22)

Page 2 of 11

PRELIMINARY TITLE

TRACTS 1-5



First American

**Commitment for Title Insurance
Indiana - 2021 v. 01.00 (07-01-2021)**

SCHEDULE B, PART I—Requirements

All of the following Requirements must be met:

1. The Proposed Insured must notify the Company in writing of the name of any party not referred to in this Commitment who will obtain an interest in the Land or who will make a loan on the Land. The Company may then make additional Requirements or Exceptions.
2. Pay the agreed amount for the estate or interest to be insured.
3. Pay the premiums, fees, and charges for the Policy to the Company.
4. Documents satisfactory to the Company that convey the Title or create the Mortgage to be insured, or both, must be properly authorized, executed, delivered, and recorded in the Public Records.
5. Note: Effective July 1, 2009, HEA 1374 (enacting Indiana Code 27-7-3.7) requires Good Funds for real estate transactions. Funds received from any party to the transaction in an amount of \$10,000 or more must be in the forms of an irrevocable wire transfer. Funds received from any party in an amount less than \$10,000 may be in the form irrevocable wire transfer, cashier's check, certified check, check drawn on the escrow account of another closing agent, or check drawn on the trust account of a licensed real estate broker or other forms of Good Funds as referenced in Indiana Code 27-7-3.7. Personal checks may be accepted as provided under Indiana Code 27-7-3.7.
6. Indiana state law, effective July 1, 2023, prohibits ownership of real property by certain foreign parties. This law can be found at Indiana Code § 1-1-16. Any loss or damage incurred as a result of a violation of this law is excluded from coverage under the terms of a title insurance policy.

If a prohibited foreign entity or person is a party to this transaction, the Company must be notified in writing. The Company will not knowingly close or insure a transaction that violates the referenced state law.

7. You must file a Disclosure of Sales Information forms prescribed by the State Board of Tax Commissioners pursuant to I.C. 6-1.1-5.5. The disclosure form must be filed with the county auditor's office prior to recording.
8. You should contact the local municipality to obtain information regarding unpaid sewer and/or municipal assessments that are not a recorded lien against the land. We are not responsible for collecting at closing such unpaid assessments unless otherwise instructed.
9. This commitment is not effective until you provide us with the name of the Proposed Insured(s) and the Policy amount(s). We limit our liability to \$250.00 until you provide us with the Policy Amount(s).
10. Vendor's and/or Mortgagor's Affidavits to be executed at the closing.

This page is only a part of a 2021 ALTA Commitment for Title Insurance issued by Metropolitan Title of Indiana, LLC on behalf of First American Title Insurance Company. This Commitment is not valid without the Notice; the Commitment to Issue Policy; the Commitment Conditions; Schedule A; Schedule B, Part I—Requirements; and Schedule B, Part II—Exceptions; and a counter-signature by the Company or its issuing agent that may be in electronic form.

Copyright 2021 American Land Title Association. All rights reserved.

The use of this Form (or any derivative thereof) is restricted to ALTA licensees and ALTA members in good standing as of the date of use. All other uses are prohibited. Reprinted under license from the American Land Title Association.

Form 50115218 (8-11-22)

Page 3 of 11

PRELIMINARY TITLE

TRACTS 1-5



First American

**Commitment for Title Insurance
Indiana - 2021 v. 01.00 (07-01-2021)**

11. Effective July 1, 2006, no document executed in the State of Indiana may be accepted for recording unless the document includes the following affirmative statement: "I affirm, under the penalties of perjury, that I have taken reasonable care to redact each Social Security number in this document, unless required by law (name)." See Indiana Code 36-2-11-15.
12. By virtue of I.C. 27-7-3.6, a fee of \$5.00 will be collected from the purchaser of the policy for each policy issued in conjunction with a closing occurring on or after July 1, 2006. The fee should be designated in the Closing Disclosure and/or Settlement Statement as TIEFF (Title Insurance Enforcement Fund Fee) Charge.
13. Note: Effective July 1, 2013 Senate Enrolled Act 370 (P.L. 80-2013) requires title insurance companies to charge a fee for closing protection letters in real estate transaction in which the title insurance company or its authorized agent acts as the settlement agent. In a residential transaction, the closing protection letters are mandatory and must be issued to each party. Insurance Company's fee for closing protection letters is \$25 for a seller's letter, \$25 for a buyer's or borrower's letter and \$25 for a lender's letter.
14. This transaction may be subject to the FinCEN Residential Real Estate Reporting Rule ("RRE Rule") issued pursuant to the Bank Secrecy Act, effective March 1, 2026. Information necessary to comply with the RRE Rule must be obtained and provided to the Reporting Person, as defined in the RRE Rule, prior to closing.

This page is only a part of a 2021 ALTA Commitment for Title Insurance issued by Metropolitan Title of Indiana, LLC on behalf of First American Title Insurance Company. This Commitment is not valid without the Notice; the Commitment to Issue Policy; the Commitment Conditions; Schedule A; Schedule B, Part I—Requirements; and Schedule B, Part II—Exceptions; and a counter-signature by the Company or its issuing agent that may be in electronic form.

Copyright 2021 American Land Title Association. All rights reserved.

The use of this Form (or any derivative thereof) is restricted to ALTA licensees and ALTA members in good standing as of the date of use. All other uses are prohibited. Reprinted under license from the American Land Title Association.

Form 50115218 (8-11-22)

Page 4 of 11

PRELIMINARY TITLE

TRACTS 1-5



First American

Commitment for Title Insurance
Indiana - 2021 v. 01.00 (07-01-2021)

SCHEDULE B, PART II—Exceptions

Some historical land records contain Discriminatory Covenants that are illegal and unenforceable by law. This Commitment and the Policy treat any Discriminatory Covenant in a document referenced in Schedule B as if each Discriminatory Covenant is redacted, repudiated, removed, and not republished or recirculated. Only the remaining provisions of the document will be excepted from coverage.

The Policy will not insure against loss or damage resulting from the terms and conditions of any lease or easement identified in Schedule A, and will include the following Exceptions unless cleared to the satisfaction of the Company:

1. Any defect, lien, encumbrance, adverse claim, or other matter that appears for the first time in the Public Records or is created, attaches, or is disclosed between the Commitment Date and the date on which all of the Schedule B, Part I—Requirements are met.
2. Any discrepancies or conflicts in boundary lines, any shortages in area, or any encroachment or overlapping in improvements.
3. Any facts, rights, interests or claims which are not shown by the Public Records but which could be ascertained by an accurate survey of the Land or by making inquiry of persons in possession of the Land.
4. Easements, liens or encumbrances or claims thereof, which are not shown by the Public Records.
5. Any lien, or right to a lien for services, labor or material imposed by law and not shown by the Public Records.
6. Taxes or special assessments which are not shown as existing liens by the Public Records.

This page is only a part of a 2021 ALTA Commitment for Title Insurance issued by Metropolitan Title of Indiana, LLC on behalf of First American Title Insurance Company. This Commitment is not valid without the Notice; the Commitment to Issue Policy; the Commitment Conditions; Schedule A; Schedule B, Part I—Requirements; and Schedule B, Part II—Exceptions; and a counter-signature by the Company or its issuing agent that may be in electronic form.

Copyright 2021 American Land Title Association. All rights reserved.

The use of this Form (or any derivative thereof) is restricted to ALTA licensees and ALTA members in good standing as of the date of use. All other uses are prohibited.
Reprinted under license from the American Land Title Association.

PRELIMINARY TITLE

TRACTS 1-5



First American

**Commitment for Title Insurance
Indiana - 2021 v. 01.00 (07-01-2021)**

7. Real estate taxes assessed for the year 2025 are due in two installments payable May 10, 2026 and November 10, 2026:

Parcel No.: 90-05-22-200-004.000-011

May Installment of \$2,045.46 shows unpaid

November Installment of \$2,045.46 shows unpaid

Tax Year:	Current Year 2025 due 2026
Land:	\$144,900.00
Improvements:	\$84,300.00
Homeowners Exemption:	\$0
Supplemental Homestead:	\$0
Other Exemption:	\$13,752.00-2% Deduction

NOTE: The taxes above are lower if tax exemptions are showing. The taxes above will increase if the seller acquired the property within the last two calendar years, and did not refile any exemptions. Contact the local Assessor if you have any questions about the current status of exemptions and how they will affect taxes payable subsequent to closing.

Taxes for the year 2026 due in May and November, 2027.

8. Johnson Drainage/Ditch Assessment: Parcel No.: 90-05-22-200-004.000-011 For the year: 2026; May installment of \$22.14 shows unpaid; November installment of \$22.14 shows unpaid.
9. The Company is advised that Dixie L. Snyder is deceased. An unsupervised estate has been opened in Wells County in Circuit Court under Cause No. 90C01-2410-EU-000040.

The Company requires that the granting clause of the deed to the grantee include substantially the following language: Michael L. Snyder and Lynette S. Mankey are the co-personal representatives of the Estate of Dixie L. Snyder, deceased. This Estate is pending as Cause Number 90C01-2410-EU-000040, in the Wells Circuit Court of the County. The Co-Personal Representatives, by virtue of the power given a personal representative under Indiana law, for good and sufficient consideration, convey to purchaser(s).

The Company reserves the right to add such further exceptions as may be appropriate if the deed will not be executed by Michael L. Snyder and Lynette S. Mankey, as Co-Personal Representatives. The attorney for the estate is Matthew Patrick Hayes/119 E Oak Forrest DR Bluffton, IN 46714. The date of death was September 12, 2024.

10. Oil and Gas Lease in favor of Nash Redwine of Mt. Vernon Illinois, as disclosed by instrument recorded in Miscellaneous Record 36, page 467. Assigned to Willis Tool Service in Miscellaneous Record 36, page 513

This page is only a part of a 2021 ALTA Commitment for Title Insurance issued by Metropolitan Title of Indiana, LLC on behalf of First American Title Insurance Company. This Commitment is not valid without the Notice; the Commitment to Issue Policy; the Commitment Conditions; Schedule A; Schedule B, Part I—Requirements; and Schedule B, Part II—Exceptions; and a counter-signature by the Company or its issuing agent that may be in electronic form.

Copyright 2021 American Land Title Association. All rights reserved.

The use of this Form (or any derivative thereof) is restricted to ALTA licensees and ALTA members in good standing as of the date of use. All other uses are prohibited. Reprinted under license from the American Land Title Association.

Form 50115218 (8-11-22)

Page 6 of 11

PRELIMINARY TITLE

TRACTS 1-5



First American

**Commitment for Title Insurance
Indiana - 2021 v. 01.00 (07-01-2021)**

11. Easement for power lines granted to Indiana Michigan Power Company, an Indiana corporation as recorded March 05, 1999 in Miscellaneous Record 61, page 946.
12. Rights of tenants, if any, under any unrecorded leases, including the right to grow, harvest, cultivate, maintain, sell & store any and all crops, timber and /or feed that was or is being grown, withdrawn or harvested on the Land.
13. Rights of the public, the State of Indiana and the municipality in and to that part of the land, if any, taken or used for road purposes, including utility right of way.
14. Minerals or mineral rights or any other subsurface substances (including, without limitation, oil, gas and coal), and all rights incident thereto, now or previously leased, granted, excepted or reserved.

NOTE: For informational purposes only and same to be omitted from the final policy, when issued:

The following are the vesting deed of record and all of the deeds, if any, affecting the Land recorded within 36 months preceding the Commitment Date hereof:

VESTING DEED

Grantor: Estate of J. Earl Elzey, deceased
Grantee: Dixie L. Snider
Date of Recording: October 09, 1985
Recorded: Deed Record 120, page 47

NOTE: The final Loan Policy will include the following Endorsements upon compliance with the Company's issuing standard:

Restrictions, Encroachments, Minerals - Loan Policy Endorsement (ALTA 9)
Environmental Protection Lien Endorsement (ALTA 8.1)

This page is only a part of a 2021 ALTA Commitment for Title Insurance issued by Metropolitan Title of Indiana, LLC on behalf of First American Title Insurance Company. This Commitment is not valid without the Notice; the Commitment to Issue Policy; the Commitment Conditions; Schedule A; Schedule B, Part I—Requirements; and Schedule B, Part II—Exceptions; and a counter-signature by the Company or its issuing agent that may be in electronic form.

Copyright 2021 American Land Title Association. All rights reserved.

The use of this Form (or any derivative thereof) is restricted to ALTA licensees and ALTA members in good standing as of the date of use. All other uses are prohibited.
Reprinted under license from the American Land Title Association.

PRELIMINARY TITLE

TRACTS 1-5



First American

Commitment for Title Insurance
Indiana - 2021 v. 01.00 (07-01-2021)

ALTA COMMITMENT FOR TITLE INSURANCE

Issued by
Metropolitan Title of Indiana, LLC
as issuing Agent for
First American Title Insurance Company

NOTICE

IMPORTANT—READ CAREFULLY: THIS COMMITMENT IS AN OFFER TO ISSUE ONE OR MORE TITLE INSURANCE POLICIES. ALL CLAIMS OR REMEDIES SOUGHT AGAINST THE COMPANY INVOLVING THE CONTENT OF THIS COMMITMENT OR THE POLICY MUST BE BASED SOLELY IN CONTRACT.

THIS COMMITMENT IS NOT AN ABSTRACT OF TITLE, REPORT OF THE CONDITION OF TITLE, LEGAL OPINION, OPINION OF TITLE, OR OTHER REPRESENTATION OF THE STATUS OF TITLE. THE PROCEDURES USED BY THE COMPANY TO DETERMINE INSURABILITY OF THE TITLE, INCLUDING ANY SEARCH AND EXAMINATION, ARE PROPRIETARY TO THE COMPANY, WERE PERFORMED SOLELY FOR THE BENEFIT OF THE COMPANY, AND CREATE NO EXTRACTIONAL LIABILITY TO ANY PERSON, INCLUDING A PROPOSED INSURED.

THE COMPANY'S OBLIGATION UNDER THIS COMMITMENT IS TO ISSUE A POLICY TO A PROPOSED INSURED IDENTIFIED IN SCHEDULE A IN ACCORDANCE WITH THE TERMS AND PROVISIONS OF THIS COMMITMENT. THE COMPANY HAS NO LIABILITY OR OBLIGATION INVOLVING THE CONTENT OF THIS COMMITMENT TO ANY OTHER PERSON.

COMMITMENT TO ISSUE POLICY

Subject to the Notice; Schedule B, Part I—Requirements; Schedule B, Part II—Exceptions; and the Commitment Conditions, First American Title Insurance Company, a Nebraska Corporation (the "Company"), commits to issue the Policy according to the terms and provisions of this Commitment. This Commitment is effective as of the Commitment Date shown in Schedule A for each Policy described in Schedule A, only when the Company has entered in Schedule A both the specified dollar amount as the Proposed Amount of Insurance and the name of the Proposed Insured.

If all of the Schedule B, Part I—Requirements have not been met within six months after the Commitment Date, this Commitment terminates and the Company's liability and obligation end.

FIRST AMERICAN TITLE INSURANCE COMPANY

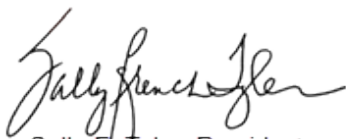
Sally F. Tyler, President

Lisa W. Cornehl, Secretary

This page is only a part of a 2021 ALTA Commitment for Title Insurance issued by Metropolitan Title of Indiana, LLC on behalf of First American Title Insurance Company. This Commitment is not valid without the Notice; the Commitment to Issue Policy; the Commitment Conditions; Schedule A; Schedule B, Part I—Requirements; and Schedule B, Part II—Exceptions; and a counter-signature by the Company or its issuing agent that may be in electronic form.

Copyright 2021 American Land Title Association. All rights reserved.

The use of this Form (or any derivative thereof) is restricted to ALTA licensees and ALTA members in good standing as of the date of use. All other uses are prohibited.
Reprinted under license from the American Land Title Association.

PRELIMINARY TITLE

TRACTS 1-5



First American

Commitment for Title Insurance
Indiana - 2021 v. 01.00 (07-01-2021)

COMMITMENT CONDITIONS

1. DEFINITIONS

- a. "Discriminatory Covenant": Any covenant, condition, restriction, or limitation that is unenforceable under applicable law because it illegally discriminates against a class of individuals based on personal characteristics such as race, color, religion, sex, sexual orientation, gender identity, familial status, disability, national origin, or other legally protected class.
- b. "Knowledge" or "Known": Actual knowledge or actual notice, but not constructive notice imparted by the Public Records.
- c. "Land": The land described in Item 5 of Schedule A and improvements located on that land that by State law constitute real property. The term "Land" does not include any property beyond that described in Schedule A, nor any right, title, interest, estate, or easement in any abutting street, road, avenue, alley, lane, right-of-way, body of water, or waterway, but does not modify or limit the extent that a right of access to and from the Land is to be insured by the Policy.
- d. "Mortgage": A mortgage, deed of trust, trust deed, security deed, or other real property security instrument, including one evidenced by electronic means authorized by law.
- e. "Policy": Each contract of title insurance, in a form adopted by the American Land Title Association, issued or to be issued by the Company pursuant to this Commitment.
- f. "Proposed Amount of Insurance": Each dollar amount specified in Schedule A as the Proposed Amount of Insurance of each Policy to be issued pursuant to this Commitment.
- g. "Proposed Insured": Each person identified in Schedule A as the Proposed Insured of each Policy to be issued pursuant to this Commitment.
- h. "Public Records": The recording or filing system established under State statutes in effect at the Commitment Date under which a document must be recorded or filed to impart constructive notice of matters relating to the Title to a purchaser for value without Knowledge. The term "Public Records" does not include any other recording or filing system, including any pertaining to environmental remediation or protection, planning, permitting, zoning, licensing, building, health, public safety, or national security matters.
- i. "State": The state or commonwealth of the United States within whose exterior boundaries the Land is located. The term "State" also includes the District of Columbia, the Commonwealth of Puerto Rico, the U.S. Virgin Islands, and Guam.
- j. "Title": The estate or interest in the Land identified in Item 3 of Schedule A.

2. If all of the Schedule B, Part I—Requirements have not been met within the time period specified in the Commitment to Issue Policy, this Commitment terminates and the Company's liability and obligation end.

3. The Company's liability and obligation is limited by and this Commitment is not valid without:

- a. the Notice;
- b. the Commitment to Issue Policy;
- c. the Commitment Conditions;
- d. Schedule A;
- e. Schedule B, Part I—Requirements;
- f. Schedule B, Part II—Exceptions; and

This page is only a part of a 2021 ALTA Commitment for Title Insurance issued by Metropolitan Title of Indiana, LLC on behalf of First American Title Insurance Company. This Commitment is not valid without the Notice; the Commitment to Issue Policy; the Commitment Conditions; Schedule A; Schedule B, Part I—Requirements; and Schedule B, Part II—Exceptions; and a counter-signature by the Company or its issuing agent that may be in electronic form.

Copyright 2021 American Land Title Association. All rights reserved.

The use of this Form (or any derivative thereof) is restricted to ALTA licensees and ALTA members in good standing as of the date of use. All other uses are prohibited. Reprinted under license from the American Land Title Association.

PRELIMINARY TITLE

TRACTS 1-5



First American

**Commitment for Title Insurance
Indiana - 2021 v. 01.00 (07-01-2021)**

- g. a counter-signature by the Company or its issuing agent that may be in electronic form.
- 4. COMPANY'S RIGHT TO AMEND**
The Company may amend this Commitment at any time. If the Company amends this Commitment to add a defect, lien, encumbrance, adverse claim, or other matter recorded in the Public Records prior to the Commitment Date, any liability of the Company is limited by Commitment Condition 5. The Company is not liable for any other amendment to this Commitment.
- 5. LIMITATIONS OF LIABILITY**
- a. The Company's liability under Commitment Condition 4 is limited to the Proposed Insured's actual expense incurred in the interval between the Company's delivery to the Proposed Insured of the Commitment and the delivery of the amended Commitment, resulting from the Proposed Insured's good faith reliance to:
- i. comply with the Schedule B, Part I—Requirements;
 - ii. eliminate, with the Company's written consent, any Schedule B, Part II—Exceptions; or
 - iii. acquire the Title or create the Mortgage covered by this Commitment.
- b. The Company is not liable under Commitment Condition 5.a. if the Proposed Insured requested the amendment or had Knowledge of the matter and did not notify the Company about it in writing.
- c. The Company is only liable under Commitment Condition 4 if the Proposed Insured would not have incurred the expense had the Commitment included the added matter when the Commitment was first delivered to the Proposed Insured.
- d. The Company's liability does not exceed the lesser of the Proposed Insured's actual expense incurred in good faith and described in Commitment Condition 5.a. or the Proposed Amount of Insurance.
- e. The Company is not liable for the content of the Transaction Identification Data, if any.
- f. The Company is not obligated to issue the Policy referred to in this Commitment unless all of the Schedule B, Part I—Requirements have been met to the satisfaction of the Company.
- g. The Company's liability is further limited by the terms and provisions of the Policy to be issued to the Proposed Insured.
- 6. LIABILITY OF THE COMPANY MUST BE BASED ON THIS COMMITMENT; CHOICE OF LAW AND CHOICE OF FORUM**
- a. Only a Proposed Insured identified in Schedule A, and no other person, may make a claim under this Commitment.
- b. Any claim must be based in contract under the State law of the State where the Land is located and is restricted to the terms and provisions of this Commitment. Any litigation or other proceeding brought by the Proposed Insured against the Company must be filed only in a State or federal court having jurisdiction.
- c. This Commitment, as last revised, is the exclusive and entire agreement between the parties with respect to the subject matter of this Commitment and supersedes all prior commitment negotiations, representations, and proposals of any kind, whether written or oral, express or implied, relating to the subject matter of this Commitment.
- d. The deletion or modification of any Schedule B, Part II—Exception does not constitute an agreement or obligation to provide coverage beyond the terms and provisions of this Commitment or the Policy.

This page is only a part of a 2021 ALTA Commitment for Title Insurance issued by Metropolitan Title of Indiana, LLC on behalf of First American Title Insurance Company. This Commitment is not valid without the Notice; the Commitment to Issue Policy; the Commitment Conditions; Schedule A; Schedule B, Part I—Requirements; and Schedule B, Part II—Exceptions; and a counter-signature by the Company or its issuing agent that may be in electronic form.

Copyright 2021 American Land Title Association. All rights reserved.

The use of this Form (or any derivative thereof) is restricted to ALTA licensees and ALTA members in good standing as of the date of use. All other uses are prohibited. Reprinted under license from the American Land Title Association.

PRELIMINARY TITLE

TRACTS 1-5



First American

**Commitment for Title Insurance
Indiana - 2021 v. 01.00 (07-01-2021)**

- e. Any amendment or endorsement to this Commitment must be in writing and authenticated by a person authorized by the Company.
 - f. When the Policy is issued, all liability and obligation under this Commitment will end and the Company's only liability will be under the Policy.
- 7. IF THIS COMMITMENT IS ISSUED BY AN ISSUING AGENT**
The issuing agent is the Company's agent only for the limited purpose of issuing title insurance commitments and policies. The issuing agent is not the Company's agent for closing, settlement, escrow, or any other purpose.
- 8. PRO-FORMA POLICY**
The Company may provide, at the request of a Proposed Insured, a pro-forma policy illustrating the coverage that the Company may provide. A pro-forma policy neither reflects the status of Title at the time that the pro-forma policy is delivered to a Proposed Insured, nor is it a commitment to insure.
- 9. CLAIMS PROCEDURES**
This Commitment incorporates by reference all Conditions for making a claim in the Policy to be issued to the Proposed Insured. Commitment Condition 9 does not modify the limitations of liability in Commitment Conditions 5 and 6.
- 10. CLASS ACTION**
ALL CLAIMS AND DISPUTES ARISING OUT OF OR RELATING TO THIS COMMITMENT, INCLUDING ANY SERVICE OR OTHER MATTER IN CONNECTION WITH ISSUING THIS COMMITMENT, ANY BREACH OF A COMMITMENT PROVISION, OR ANY OTHER CLAIM OR DISPUTE ARISING OUT OF OR RELATING TO THE TRANSACTION GIVING RISE TO THIS COMMITMENT, MUST BE BROUGHT IN AN INDIVIDUAL CAPACITY. NO PARTY MAY SERVE AS PLAINTIFF, CLASS MEMBER, OR PARTICIPANT IN ANY CLASS OR REPRESENTATIVE PROCEEDING. ANY POLICY ISSUED PURSUANT TO THIS COMMITMENT WILL CONTAIN A CLASS ACTION CONDITION.
- 11. ARBITRATION**
The Policy contains an arbitration clause. All arbitrable matters when the Proposed Amount of Insurance is \$2,000,000 or less may be arbitrated at the election of either the Company or the Proposed Insured as the exclusive remedy of the parties. A Proposed Insured may review a copy of the arbitration rules at <http://www.alta.org/arbitration>.

This page is only a part of a 2021 ALTA Commitment for Title Insurance issued by Metropolitan Title of Indiana, LLC on behalf of First American Title Insurance Company. This Commitment is not valid without the Notice; the Commitment to Issue Policy; the Commitment Conditions; Schedule A; Schedule B, Part I—Requirements; and Schedule B, Part II—Exceptions; and a counter-signature by the Company or its issuing agent that may be in electronic form.

Copyright 2021 American Land Title Association. All rights reserved.

The use of this Form (or any derivative thereof) is restricted to ALTA licensees and ALTA members in good standing as of the date of use. All other uses are prohibited. Reprinted under license from the American Land Title Association.

PRELIMINARY TITLE

TRACT 6



First American

**Commitment for Title Insurance
Indiana - 2021 v. 01.00 (07-01-2021)**

ANY PERSON WHO, WITH INTENT TO DEFRAUD OR KNOWING THAT HE IS FACILITATING A FRAUD AGAINST AN INSURER, SUBMITS AN APPLICATION OR FILES A CLAIM CONTAINING A FALSE OR DECEPTIVE STATEMENT IS GUILTY OF INSURANCE FRAUD.

Transaction Identification Data, for which the Company assumes no liability as set forth in Commitment Condition 5.e.:

Issuing Agent: Metropolitan Title of Indiana, LLC
Issuing Office: 117 S. Johnson St., Bluffton, IN 46714
Issuing Office File Number: 4035-281915
Property Address: 350 E. Jackson, Bluffton, IN 46714
Revision Number:



SCHEDULE A

1. Commitment Date: March 18, 2026 at 8:00 a.m.
2. Policy to be issued:
 - a. ALTA® Standard Owner's Policy
Proposed Insured: To Be Determined
Proposed Amount of Insurance: \$500.00
The estate or interest to be insured: See Item 3 below
 - b. ALTA® Standard Loan Policy
Proposed Insured: TBD - Lender, its successors and/or assigns that are defined as an insured in the Conditions of the policy, as their interests may appear
Proposed Amount of Insurance: \$500.00
The estate or interest to be insured: See Item 3 below
3. The estate or interest in the Land at the Commitment Date is:

Fee Simple
4. The Title is, at the Commitment Date, vested in:

Devises under the Last Will and Testament of Dixie L. Snider, deceased
5. The Land is described as follows:

Situated in the County of Wells, State of Indiana, is described as follows:

This page is only a part of a 2021 ALTA Commitment for Title Insurance issued by Metropolitan Title of Indiana, LLC on behalf of First American Title Insurance Company. This Commitment is not valid without the Notice; the Commitment to Issue Policy; the Commitment Conditions; Schedule A; Schedule B, Part I—Requirements; and Schedule B, Part II—Exceptions; and a counter-signature by the Company or its issuing agent that may be in electronic form.

Copyright 2021 American Land Title Association. All rights reserved.

The use of this Form (or any derivative thereof) is restricted to ALTA licensees and ALTA members in good standing as of the date of use. All other uses are prohibited.
Reprinted under license from the American Land Title Association.

Form 50115218 (8-11-22)

Page 1 of 12

PRELIMINARY TITLE

TRACT 6



First American

Commitment for Title Insurance
Indiana - 2021 v. 01.00 (07-01-2021)

Part of the Northwest Quarter of Section 22, Township 27 North, Range 12 East, Lancaster Township, Wells County, Indiana, described as follows:

Starting at the Northeast corner of said Northwest Quarter found per record witness; thence Westerly, 853.74 feet along the North line of said Northwest Quarter to the place of beginning; thence Southerly, deflecting left 89 degrees 13 minutes 00 seconds, 162.00 feet; thence Southeasterly, deflecting left 23 degrees 53 minutes 20 seconds, 30.00 feet; thence Southerly, deflecting right 24 degrees 37 minutes 18 seconds, 1729.47 feet; thence Easterly, deflecting left 87 degrees 58 minutes 56 seconds, 11.90 feet; thence Southeasterly, deflecting right 42 degrees 07 minutes 15 seconds, 742.23 feet; thence Southerly, deflecting right 42 degrees 49 minutes 06 seconds, 218.51 feet to the South line of said Northwest Quarter; thence Westerly, deflecting right 92 degrees 39 minutes 43 seconds, 1056.00 feet along said South line to a concrete post at the Southwest corner of the East half of said Northwest Quarter; thence Northerly, deflecting right 90 degrees 42 minutes 58 seconds, 760.00 feet along the West line of said East half; thence Easterly, deflecting right 91 degrees 41 minutes 00 seconds, 470.67 feet; thence Northerly, deflecting left 92 degrees 01 minutes 04 seconds, 1728.25 feet; thence northwesterly, deflecting left 24 degrees 37 minutes 18 seconds, 30.00 feet; thence Northerly, deflecting right 24 degrees 37 minutes 18 seconds, 162.00 feet to the North line of said Northwest Quarter; thence Easterly, deflecting right 89 degrees 13 minutes 00 seconds, 25.00 feet along said North line to the place of beginning.
CONTAINING 15.75 ACRES.

This page is only a part of a 2021 ALTA Commitment for Title Insurance issued by Metropolitan Title of Indiana, LLC on behalf of First American Title Insurance Company. This Commitment is not valid without the Notice; the Commitment to Issue Policy; the Commitment Conditions; Schedule A; Schedule B, Part I—Requirements; and Schedule B, Part II—Exceptions; and a counter-signature by the Company or its issuing agent that may be in electronic form.

Copyright 2021 American Land Title Association. All rights reserved.

The use of this Form (or any derivative thereof) is restricted to ALTA licensees and ALTA members in good standing as of the date of use. All other uses are prohibited.
Reprinted under license from the American Land Title Association.

PRELIMINARY TITLE

TRACT 6



First American

Commitment for Title Insurance
Indiana - 2021 v. 01.00 (07-01-2021)

SCHEDULE B, PART I—Requirements

All of the following Requirements must be met:

1. The Proposed Insured must notify the Company in writing of the name of any party not referred to in this Commitment who will obtain an interest in the Land or who will make a loan on the Land. The Company may then make additional Requirements or Exceptions.
2. Pay the agreed amount for the estate or interest to be insured.
3. Pay the premiums, fees, and charges for the Policy to the Company.
4. Documents satisfactory to the Company that convey the Title or create the Mortgage to be insured, or both, must be properly authorized, executed, delivered, and recorded in the Public Records.
5. Note: Effective July 1, 2009, HEA 1374 (enacting Indiana Code 27-7-3.7) requires Good Funds for real estate transactions. Funds received from any party to the transaction in an amount of \$10,000 or more must be in the forms of an irrevocable wire transfer. Funds received from any party in an amount less than \$10,000 may be in the form irrevocable wire transfer, cashier's check, certified check, check drawn on the escrow account of another closing agent, or check drawn on the trust account of a licensed real estate broker or other forms of Good Funds as referenced in Indiana Code 27-7-3.7. Personal checks may be accepted as provided under Indiana Code 27-7-3.7.
6. Indiana state law, effective July 1, 2023, prohibits ownership of real property by certain foreign parties. This law can be found at Indiana Code § 1-1-16. Any loss or damage incurred as a result of a violation of this law is excluded from coverage under the terms of a title insurance policy.

If a prohibited foreign entity or person is a party to this transaction, the Company must be notified in writing. The Company will not knowingly close or insure a transaction that violates the referenced state law.

7. You must file a Disclosure of Sales Information forms prescribed by the State Board of Tax Commissioners pursuant to I.C. 6-1.1-5.5. The disclosure form must be filed with the county auditor's office prior to recording.
8. You should contact the local municipality to obtain information regarding unpaid sewer and/or municipal assessments that are not a recorded lien against the land. We are not responsible for collecting at closing such unpaid assessments unless otherwise instructed.
9. This commitment is not effective until you provide us with the name of the Proposed Insured(s) and the Policy amount(s). We limit our liability to \$250.00 until you provide us with the Policy Amount(s).
10. Vendor's and/or Mortgagor's Affidavits to be executed at the closing.

This page is only a part of a 2021 ALTA Commitment for Title Insurance issued by Metropolitan Title of Indiana, LLC on behalf of First American Title Insurance Company. This Commitment is not valid without the Notice; the Commitment to Issue Policy; the Commitment Conditions; Schedule A; Schedule B, Part I—Requirements; and Schedule B, Part II—Exceptions; and a counter-signature by the Company or its issuing agent that may be in electronic form.

Copyright 2021 American Land Title Association. All rights reserved.

The use of this Form (or any derivative thereof) is restricted to ALTA licensees and ALTA members in good standing as of the date of use. All other uses are prohibited. Reprinted under license from the American Land Title Association.

Form 50115218 (8-11-22)

Page 3 of 12

PRELIMINARY TITLE

TRACT 6



First American

**Commitment for Title Insurance
Indiana - 2021 v. 01.00 (07-01-2021)**

11. Effective July 1, 2006, no document executed in the State of Indiana may be accepted for recording unless the document includes the following affirmative statement: "I affirm, under the penalties of perjury, that I have taken reasonable care to redact each Social Security number in this document, unless required by law (name)." See Indiana Code 36-2-11-15.
12. By virtue of I.C. 27-7-3.6, a fee of \$5.00 will be collected from the purchaser of the policy for each policy issued in conjunction with a closing occurring on or after July 1, 2006. The fee should be designated in the Closing Disclosure and/or Settlement Statement as TIEFF (Title Insurance Enforcement Fund Fee) Charge.
13. Note: Effective July 1, 2013 Senate Enrolled Act 370 (P.L. 80-2013) requires title insurance companies to charge a fee for closing protection letters in real estate transaction in which the title insurance company or its authorized agent acts as the settlement agent. In a residential transaction, the closing protection letters are mandatory and must be issued to each party. Insurance Company's fee for closing protection letters is \$25 for a seller's letter, \$25 for a buyer's or borrower's letter and \$25 for a lender's letter.
14. This transaction may be subject to the FinCEN Residential Real Estate Reporting Rule ("RRE Rule") issued pursuant to the Bank Secrecy Act, effective March 1, 2026. Information necessary to comply with the RRE Rule must be obtained and provided to the Reporting Person, as defined in the RRE Rule, prior to closing.

This page is only a part of a 2021 ALTA Commitment for Title Insurance issued by Metropolitan Title of Indiana, LLC on behalf of First American Title Insurance Company. This Commitment is not valid without the Notice; the Commitment to Issue Policy; the Commitment Conditions; Schedule A; Schedule B, Part I—Requirements; and Schedule B, Part II—Exceptions; and a counter-signature by the Company or its issuing agent that may be in electronic form.

Copyright 2021 American Land Title Association. All rights reserved.

The use of this Form (or any derivative thereof) is restricted to ALTA licensees and ALTA members in good standing as of the date of use. All other uses are prohibited. Reprinted under license from the American Land Title Association.

Form 50115218 (8-11-22)

Page 4 of 12

PRELIMINARY TITLE

TRACT 6



First American

Commitment for Title Insurance
Indiana - 2021 v. 01.00 (07-01-2021)

SCHEDULE B, PART II—Exceptions

Some historical land records contain Discriminatory Covenants that are illegal and unenforceable by law. This Commitment and the Policy treat any Discriminatory Covenant in a document referenced in Schedule B as if each Discriminatory Covenant is redacted, repudiated, removed, and not republished or recirculated. Only the remaining provisions of the document will be excepted from coverage.

The Policy will not insure against loss or damage resulting from the terms and conditions of any lease or easement identified in Schedule A, and will include the following Exceptions unless cleared to the satisfaction of the Company:

1. Any defect, lien, encumbrance, adverse claim, or other matter that appears for the first time in the Public Records or is created, attaches, or is disclosed between the Commitment Date and the date on which all of the Schedule B, Part I—Requirements are met.
2. Any discrepancies or conflicts in boundary lines, any shortages in area, or any encroachment or overlapping in improvements.
3. Any facts, rights, interests or claims which are not shown by the Public Records but which could be ascertained by an accurate survey of the Land or by making inquiry of persons in possession of the Land.
4. Easements, liens or encumbrances or claims thereof, which are not shown by the Public Records.
5. Any lien, or right to a lien for services, labor or material imposed by law and not shown by the Public Records.
6. Taxes or special assessments which are not shown as existing liens by the Public Records.

This page is only a part of a 2021 ALTA Commitment for Title Insurance issued by Metropolitan Title of Indiana, LLC on behalf of First American Title Insurance Company. This Commitment is not valid without the Notice; the Commitment to Issue Policy; the Commitment Conditions; Schedule A; Schedule B, Part I—Requirements; and Schedule B, Part II—Exceptions; and a counter-signature by the Company or its issuing agent that may be in electronic form.

Copyright 2021 American Land Title Association. All rights reserved.

The use of this Form (or any derivative thereof) is restricted to ALTA licensees and ALTA members in good standing as of the date of use. All other uses are prohibited.
Reprinted under license from the American Land Title Association.

PRELIMINARY TITLE

TRACT 6



First American

**Commitment for Title Insurance
Indiana - 2021 v. 01.00 (07-01-2021)**

7. Real estate taxes assessed for the year 2025 are due in two installments payable May 10, 2026 and November 10, 2026:
- Parcel No.: 90-05-22-200-005.000-011
May Installment of \$5,675.89 shows unpaid
November Installment of \$5,675.89 shows unpaid

Tax Year:	Current Year 2025 due 2026
Land:	\$120,800.00
Improvements:	\$515,200.00
Homeowners Exemption:	\$0
Supplemental Homestead:	\$0
Other Exemption:	\$38,160.00-2% Deduction

NOTE: The taxes above are lower if tax exemptions are showing. The taxes above will increase if the seller acquired the property within the last two calendar years, and did not refile any exemptions. Contact the local Assessor if you have any questions about the current status of exemptions and how they will affect taxes payable subsequent to closing.

Taxes for the year 2026 due in May and November, 2027.

8. Annual assessment for the maintenance of Johnson Ditch due May 10, 2026, in the amount of \$15.00 shows unpaid.
Note: Subsequent assessments as required.
9. The Company is advised that Dixie L. Snyder is deceased. An unsupervised estate has been opened in Wells County in Circuit Court under Cause No. 90C01-2410-EU-000040.

The Company requires that the granting clause of the deed to the grantee include substantially the following language: Michael L. Snyder and Lynette S. Mankey are the co-personal representatives of the Estate of Dixie L. Snyder, deceased. This Estate is pending as Cause Number 90C01-2410-EU-000040, in the Wells Circuit Court of the County. The Co-Personal Representatives, by virtue of the power given a personal representative under Indiana law, for good and sufficient consideration, convey to purchaser(s).

The Company reserves the right to add such further exceptions as may be appropriate if the deed will not be executed by Michael L. Snyder and Lynette S. Mankey, as Co-Personal Representatives. The attorney for the estate is Matthew Patrick Hayes/119 E Oak Forrest DR Bluffton, IN 46714. The date of death was September 12, 2024.

This page is only a part of a 2021 ALTA Commitment for Title Insurance issued by Metropolitan Title of Indiana, LLC on behalf of First American Title Insurance Company. This Commitment is not valid without the Notice; the Commitment to Issue Policy; the Commitment Conditions; Schedule A; Schedule B, Part I—Requirements; and Schedule B, Part II—Exceptions; and a counter-signature by the Company or its issuing agent that may be in electronic form.

Copyright 2021 American Land Title Association. All rights reserved.

The use of this Form (or any derivative thereof) is restricted to ALTA licensees and ALTA members in good standing as of the date of use. All other uses are prohibited. Reprinted under license from the American Land Title Association.

PRELIMINARY TITLE

TRACT 6



First American

**Commitment for Title Insurance
Indiana - 2021 v. 01.00 (07-01-2021)**

10. It appears that Edwin L. Snider who acquired title to said premises with Dixie L. Snyder by a deed dated February 11, 1999 and recorded February 11, 1999 in the Office of the Recorder of the County, as Instrument No. Deed Record 135, page 307 is deceased. The Company requires that satisfactory evidence of the date of his death and that said Edwin L. Snider and Dixie L. Snyder remained husband and wife continuously from the date they acquired title to said premises until the date of the death of said Edwin L. Snider be recorded in the Office of the Recorder of the County.
11. Subject to a 20 foot wide utility easement as described in a Warranty Deed recorded February 11, 1999 in Deed Record 135, page 307.
12. Oil and Gas Lease in favor of Nash Redwine of Mt. Vernon Illinois, as disclosed by instrument recorded in Miscellaneous Record 36, page 467. Assigned to Willis Tool Service in Miscellaneous Record 36, page 513
13. Easement for power lines granted to Indiana Michigan Power Company, an Indiana corporation as recorded March 05, 1999 in Miscellaneous Record 61, page 946.
14. Terms, conditions and provisions of a Variance to increase height and square footage of accessory structure, dated July 22, 2004, recorded September 09, 2004, in Miscellaneous Record 65, page 164.
15. Terms, conditions and provisions of an Encroachment Agreement dated May 05, 2023, recorded May 09, 2023, in 20231403.
16. Survey by Joel A. Hoehn, RLS, dtaed January 06, 1999, recorded February 06, 2004 in Miscellaneous Record 64, page 880.
17. Rights of tenants, if any, under any unrecorded leases.
18. Rights of the public, the State of Indiana and the municipality in and to that part of the land, if any, taken or used for road purposes, including utility right of way.
19. Minerals or mineral rights or any other subsurface substances (including, without limitation, oil, gas and coal), and all rights incident thereto, now or previously leased, granted, excepted or reserved.

NOTE: For informational purposes only and same to be omitted from the final policy, when issued:

The following are the vesting deed of record and all of the deeds, if any, affecting the Land recorded within 36 months preceding the Commitment Date hereof:

VESTING DEED

Grantor: Dixie L. Snyder
Grantee: Edwin L. Snider and Dixie L. Snider, husband and wife
Date of Recording: February 11, 1999
Recorded: Deed Record 135, page 307

This page is only a part of a 2021 ALTA Commitment for Title Insurance issued by Metropolitan Title of Indiana, LLC on behalf of First American Title Insurance Company. This Commitment is not valid without the Notice; the Commitment to Issue Policy; the Commitment Conditions; Schedule A; Schedule B, Part I—Requirements; and Schedule B, Part II—Exceptions; and a counter-signature by the Company or its issuing agent that may be in electronic form.

Copyright 2021 American Land Title Association. All rights reserved.

The use of this Form (or any derivative thereof) is restricted to ALTA licensees and ALTA members in good standing as of the date of use. All other uses are prohibited. Reprinted under license from the American Land Title Association.

PRELIMINARY TITLE

TRACT 6



First American

**Commitment for Title Insurance
Indiana - 2021 v. 01.00 (07-01-2021)**

NOTE: The final Loan Policy will include the following Endorsements upon compliance with the Company's issuing standard:
Restrictions, Encroachments, Minerals - Loan Policy Endorsement (ALTA 9)
Environmental Protection Lien Endorsement (ALTA 8.1)

This page is only a part of a 2021 ALTA Commitment for Title Insurance issued by Metropolitan Title of Indiana, LLC on behalf of First American Title Insurance Company. This Commitment is not valid without the Notice; the Commitment to Issue Policy; the Commitment Conditions; Schedule A; Schedule B, Part I—Requirements; and Schedule B, Part II—Exceptions; and a counter-signature by the Company or its issuing agent that may be in electronic form.

Copyright 2021 American Land Title Association. All rights reserved.

The use of this Form (or any derivative thereof) is restricted to ALTA licensees and ALTA members in good standing as of the date of use. All other uses are prohibited.
Reprinted under license from the American Land Title Association.

Form 50115218 (8-11-22)

Page 8 of 12

PRELIMINARY TITLE

TRACT 6



First American

Commitment for Title Insurance
Indiana - 2021 v. 01.00 (07-01-2021)

ALTA COMMITMENT FOR TITLE INSURANCE

Issued by
Metropolitan Title of Indiana, LLC
as issuing Agent for
First American Title Insurance Company

NOTICE

IMPORTANT—READ CAREFULLY: THIS COMMITMENT IS AN OFFER TO ISSUE ONE OR MORE TITLE INSURANCE POLICIES. ALL CLAIMS OR REMEDIES SOUGHT AGAINST THE COMPANY INVOLVING THE CONTENT OF THIS COMMITMENT OR THE POLICY MUST BE BASED SOLELY IN CONTRACT.

THIS COMMITMENT IS NOT AN ABSTRACT OF TITLE, REPORT OF THE CONDITION OF TITLE, LEGAL OPINION, OPINION OF TITLE, OR OTHER REPRESENTATION OF THE STATUS OF TITLE. THE PROCEDURES USED BY THE COMPANY TO DETERMINE INSURABILITY OF THE TITLE, INCLUDING ANY SEARCH AND EXAMINATION, ARE PROPRIETARY TO THE COMPANY, WERE PERFORMED SOLELY FOR THE BENEFIT OF THE COMPANY, AND CREATE NO EXTRACTIONAL LIABILITY TO ANY PERSON, INCLUDING A PROPOSED INSURED.

THE COMPANY'S OBLIGATION UNDER THIS COMMITMENT IS TO ISSUE A POLICY TO A PROPOSED INSURED IDENTIFIED IN SCHEDULE A IN ACCORDANCE WITH THE TERMS AND PROVISIONS OF THIS COMMITMENT. THE COMPANY HAS NO LIABILITY OR OBLIGATION INVOLVING THE CONTENT OF THIS COMMITMENT TO ANY OTHER PERSON.

COMMITMENT TO ISSUE POLICY

Subject to the Notice; Schedule B, Part I—Requirements; Schedule B, Part II—Exceptions; and the Commitment Conditions, First American Title Insurance Company, a Nebraska Corporation (the "Company"), commits to issue the Policy according to the terms and provisions of this Commitment. This Commitment is effective as of the Commitment Date shown in Schedule A for each Policy described in Schedule A, only when the Company has entered in Schedule A both the specified dollar amount as the Proposed Amount of Insurance and the name of the Proposed Insured.

If all of the Schedule B, Part I—Requirements have not been met within six months after the Commitment Date, this Commitment terminates and the Company's liability and obligation end.

FIRST AMERICAN TITLE INSURANCE COMPANY

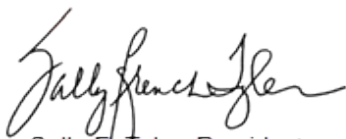
Sally F. Tyler, President

Lisa W. Cornehl, Secretary

This page is only a part of a 2021 ALTA Commitment for Title Insurance issued by Metropolitan Title of Indiana, LLC on behalf of First American Title Insurance Company. This Commitment is not valid without the Notice; the Commitment to Issue Policy; the Commitment Conditions; Schedule A; Schedule B, Part I—Requirements; and Schedule B, Part II—Exceptions; and a counter-signature by the Company or its issuing agent that may be in electronic form.

Copyright 2021 American Land Title Association. All rights reserved.

The use of this Form (or any derivative thereof) is restricted to ALTA licensees and ALTA members in good standing as of the date of use. All other uses are prohibited.
Reprinted under license from the American Land Title Association.

PRELIMINARY TITLE

TRACT 6



First American

Commitment for Title Insurance
Indiana - 2021 v. 01.00 (07-01-2021)

COMMITMENT CONDITIONS

1. DEFINITIONS

- a. "Discriminatory Covenant": Any covenant, condition, restriction, or limitation that is unenforceable under applicable law because it illegally discriminates against a class of individuals based on personal characteristics such as race, color, religion, sex, sexual orientation, gender identity, familial status, disability, national origin, or other legally protected class.
- b. "Knowledge" or "Known": Actual knowledge or actual notice, but not constructive notice imparted by the Public Records.
- c. "Land": The land described in Item 5 of Schedule A and improvements located on that land that by State law constitute real property. The term "Land" does not include any property beyond that described in Schedule A, nor any right, title, interest, estate, or easement in any abutting street, road, avenue, alley, lane, right-of-way, body of water, or waterway, but does not modify or limit the extent that a right of access to and from the Land is to be insured by the Policy.
- d. "Mortgage": A mortgage, deed of trust, trust deed, security deed, or other real property security instrument, including one evidenced by electronic means authorized by law.
- e. "Policy": Each contract of title insurance, in a form adopted by the American Land Title Association, issued or to be issued by the Company pursuant to this Commitment.
- f. "Proposed Amount of Insurance": Each dollar amount specified in Schedule A as the Proposed Amount of Insurance of each Policy to be issued pursuant to this Commitment.
- g. "Proposed Insured": Each person identified in Schedule A as the Proposed Insured of each Policy to be issued pursuant to this Commitment.
- h. "Public Records": The recording or filing system established under State statutes in effect at the Commitment Date under which a document must be recorded or filed to impart constructive notice of matters relating to the Title to a purchaser for value without Knowledge. The term "Public Records" does not include any other recording or filing system, including any pertaining to environmental remediation or protection, planning, permitting, zoning, licensing, building, health, public safety, or national security matters.
- i. "State": The state or commonwealth of the United States within whose exterior boundaries the Land is located. The term "State" also includes the District of Columbia, the Commonwealth of Puerto Rico, the U.S. Virgin Islands, and Guam.
- j. "Title": The estate or interest in the Land identified in Item 3 of Schedule A.

2. If all of the Schedule B, Part I—Requirements have not been met within the time period specified in the Commitment to Issue Policy, this Commitment terminates and the Company's liability and obligation end.

3. The Company's liability and obligation is limited by and this Commitment is not valid without:

- a. the Notice;
- b. the Commitment to Issue Policy;
- c. the Commitment Conditions;
- d. Schedule A;
- e. Schedule B, Part I—Requirements;
- f. Schedule B, Part II—Exceptions; and

This page is only a part of a 2021 ALTA Commitment for Title Insurance issued by Metropolitan Title of Indiana, LLC on behalf of First American Title Insurance Company. This Commitment is not valid without the Notice; the Commitment to Issue Policy; the Commitment Conditions; Schedule A; Schedule B, Part I—Requirements; and Schedule B, Part II—Exceptions; and a counter-signature by the Company or its issuing agent that may be in electronic form.

Copyright 2021 American Land Title Association. All rights reserved.

The use of this Form (or any derivative thereof) is restricted to ALTA licensees and ALTA members in good standing as of the date of use. All other uses are prohibited. Reprinted under license from the American Land Title Association.

PRELIMINARY TITLE

TRACT 6



First American

**Commitment for Title Insurance
Indiana - 2021 v. 01.00 (07-01-2021)**

- g. a counter-signature by the Company or its issuing agent that may be in electronic form.
- 4. COMPANY'S RIGHT TO AMEND**
The Company may amend this Commitment at any time. If the Company amends this Commitment to add a defect, lien, encumbrance, adverse claim, or other matter recorded in the Public Records prior to the Commitment Date, any liability of the Company is limited by Commitment Condition 5. The Company is not liable for any other amendment to this Commitment.
- 5. LIMITATIONS OF LIABILITY**
- a. The Company's liability under Commitment Condition 4 is limited to the Proposed Insured's actual expense incurred in the interval between the Company's delivery to the Proposed Insured of the Commitment and the delivery of the amended Commitment, resulting from the Proposed Insured's good faith reliance to:
- i. comply with the Schedule B, Part I—Requirements;
 - ii. eliminate, with the Company's written consent, any Schedule B, Part II—Exceptions; or
 - iii. acquire the Title or create the Mortgage covered by this Commitment.
- b. The Company is not liable under Commitment Condition 5.a. if the Proposed Insured requested the amendment or had Knowledge of the matter and did not notify the Company about it in writing.
- c. The Company is only liable under Commitment Condition 4 if the Proposed Insured would not have incurred the expense had the Commitment included the added matter when the Commitment was first delivered to the Proposed Insured.
- d. The Company's liability does not exceed the lesser of the Proposed Insured's actual expense incurred in good faith and described in Commitment Condition 5.a. or the Proposed Amount of Insurance.
- e. The Company is not liable for the content of the Transaction Identification Data, if any.
- f. The Company is not obligated to issue the Policy referred to in this Commitment unless all of the Schedule B, Part I—Requirements have been met to the satisfaction of the Company.
- g. The Company's liability is further limited by the terms and provisions of the Policy to be issued to the Proposed Insured.
- 6. LIABILITY OF THE COMPANY MUST BE BASED ON THIS COMMITMENT; CHOICE OF LAW AND CHOICE OF FORUM**
- a. Only a Proposed Insured identified in Schedule A, and no other person, may make a claim under this Commitment.
- b. Any claim must be based in contract under the State law of the State where the Land is located and is restricted to the terms and provisions of this Commitment. Any litigation or other proceeding brought by the Proposed Insured against the Company must be filed only in a State or federal court having jurisdiction.
- c. This Commitment, as last revised, is the exclusive and entire agreement between the parties with respect to the subject matter of this Commitment and supersedes all prior commitment negotiations, representations, and proposals of any kind, whether written or oral, express or implied, relating to the subject matter of this Commitment.
- d. The deletion or modification of any Schedule B, Part II—Exception does not constitute an agreement or obligation to provide coverage beyond the terms and provisions of this Commitment or the Policy.

This page is only a part of a 2021 ALTA Commitment for Title Insurance issued by Metropolitan Title of Indiana, LLC on behalf of First American Title Insurance Company. This Commitment is not valid without the Notice; the Commitment to Issue Policy; the Commitment Conditions; Schedule A; Schedule B, Part I—Requirements; and Schedule B, Part II—Exceptions; and a counter-signature by the Company or its issuing agent that may be in electronic form.

Copyright 2021 American Land Title Association. All rights reserved.

The use of this Form (or any derivative thereof) is restricted to ALTA licensees and ALTA members in good standing as of the date of use. All other uses are prohibited. Reprinted under license from the American Land Title Association.

PRELIMINARY TITLE

TRACT 6



First American

**Commitment for Title Insurance
Indiana - 2021 v. 01.00 (07-01-2021)**

- e. Any amendment or endorsement to this Commitment must be in writing and authenticated by a person authorized by the Company.
 - f. When the Policy is issued, all liability and obligation under this Commitment will end and the Company's only liability will be under the Policy.
- 7. IF THIS COMMITMENT IS ISSUED BY AN ISSUING AGENT**
The issuing agent is the Company's agent only for the limited purpose of issuing title insurance commitments and policies. The issuing agent is not the Company's agent for closing, settlement, escrow, or any other purpose.
- 8. PRO-FORMA POLICY**
The Company may provide, at the request of a Proposed Insured, a pro-forma policy illustrating the coverage that the Company may provide. A pro-forma policy neither reflects the status of Title at the time that the pro-forma policy is delivered to a Proposed Insured, nor is it a commitment to insure.
- 9. CLAIMS PROCEDURES**
This Commitment incorporates by reference all Conditions for making a claim in the Policy to be issued to the Proposed Insured. Commitment Condition 9 does not modify the limitations of liability in Commitment Conditions 5 and 6.
- 10. CLASS ACTION**
ALL CLAIMS AND DISPUTES ARISING OUT OF OR RELATING TO THIS COMMITMENT, INCLUDING ANY SERVICE OR OTHER MATTER IN CONNECTION WITH ISSUING THIS COMMITMENT, ANY BREACH OF A COMMITMENT PROVISION, OR ANY OTHER CLAIM OR DISPUTE ARISING OUT OF OR RELATING TO THE TRANSACTION GIVING RISE TO THIS COMMITMENT, MUST BE BROUGHT IN AN INDIVIDUAL CAPACITY. NO PARTY MAY SERVE AS PLAINTIFF, CLASS MEMBER, OR PARTICIPANT IN ANY CLASS OR REPRESENTATIVE PROCEEDING. ANY POLICY ISSUED PURSUANT TO THIS COMMITMENT WILL CONTAIN A CLASS ACTION CONDITION.
- 11. ARBITRATION**
The Policy contains an arbitration clause. All arbitrable matters when the Proposed Amount of Insurance is \$2,000,000 or less may be arbitrated at the election of either the Company or the Proposed Insured as the exclusive remedy of the parties. A Proposed Insured may review a copy of the arbitration rules at <http://www.alta.org/arbitration>.

This page is only a part of a 2021 ALTA Commitment for Title Insurance issued by Metropolitan Title of Indiana, LLC on behalf of First American Title Insurance Company. This Commitment is not valid without the Notice; the Commitment to Issue Policy; the Commitment Conditions; Schedule A; Schedule B, Part I—Requirements; and Schedule B, Part II—Exceptions; and a counter-signature by the Company or its issuing agent that may be in electronic form.

Copyright 2021 American Land Title Association. All rights reserved.

The use of this Form (or any derivative thereof) is restricted to ALTA licensees and ALTA members in good standing as of the date of use. All other uses are prohibited. Reprinted under license from the American Land Title Association.

PROPERTY PHOTOS

TRACTS 1-6



TRACTS 1, 3-5



TRACTS 1-5



TRACTS 3-4



TRACT 3



TRACT 3



TRACTS 4-5



TRACT 6 DRIVEWAY

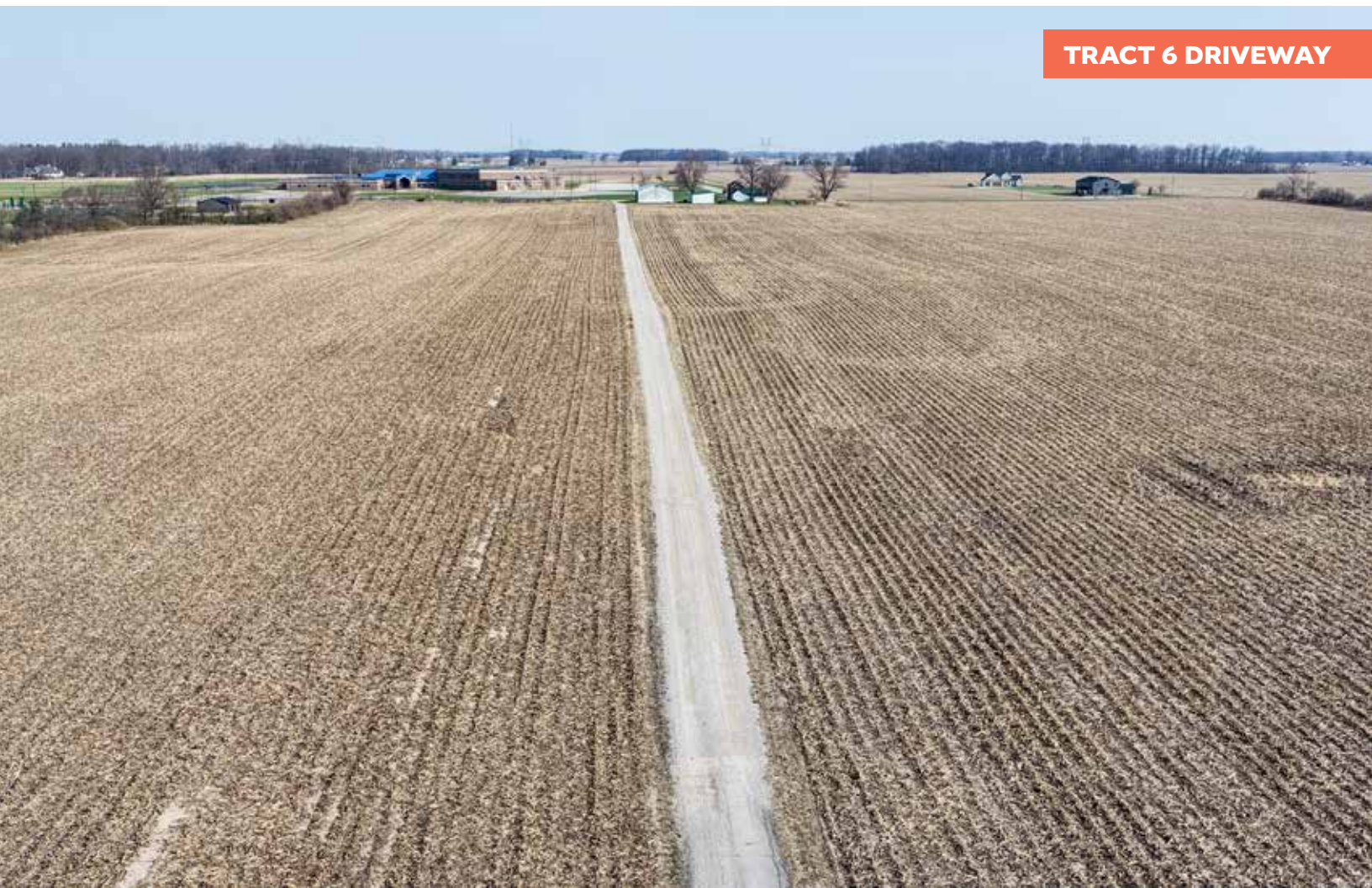

TRACT 6



TRACT 6



TRACT 6



TRACT 6



TRACT 6



TRACT 6





TRACT 6



TRACT 6





TRACT 6



TRACT 6

TRACT 6



TRACT 6





TRACT 6



TRACT 6







Auction Managers:

Al Pfister • 260.760.8922

Albert L. Pfister #RB14022767, #AU09200264

Mike Roy • 260.437.5428

Michael L. Roy #RB14049188, #AU08602044



950 North Liberty Drive, Columbia City, IN 46725
800.451.2709 • 260.244.7606 • www.schraderauction.com



CO81291723, AC63001504, RC26-572